



AGRU Piping systems for underground fire protection

PRODUCTS APPROVED
ACCORDING TO FM 1613



OUR
PRODUCTS
ARE AS
MANIFOLD
AS YOUR
DEMANDS.



www.agru.at



The Plastics Experts.



The Plastics Experts

AGRU Kunststofftechnik GmbH is an Austrian company. AGRU proves its competence and innovation in the development and production of high-quality products which are made of thermo-plastic polymers, for almost 50 years.

The product group AGRULINE offers a complete and first-class range of pipes, fittings, valves and special parts made of poly-ethylene for the environmentally friendly and safe supply of natural gas and potable water as well as the disposal of sewerage. The most modern machinery and well-trained special staff ensure production of highest grade products.



FM approved PE 100-RC pipes and fittings

Many industrial companies operate special fire-fighting systems to prevent property losses. A complete fire-fighting system needs underground pipelines (main lines) with easy accessible fire hydrant connections. The material PE 100-RC is slowly advancing to one of the most used materials for fire-fighting applications. AGRU offers one of the most complete product ranges of FM approved PE 100-RC pipes and fittings for underground fire service mains worldwide. Customers from various business fields trust into AGRUs' high quality products and its years of experience. Both of it leads to a perfect solution. That makes AGRU the reliable partner when it comes to prevent property loss.

1	Factory Mutual	04
1.1	Ensuring Quality, Dependability and Performance	04
1.2	Benefits of FM approved products	04
1.3	Standard	04
1.4	Firefighting lines	04
2	Material PE 100-RC	05
3	Chemical Resistance	06
4	Quality Assurance	06
5	Marking	07
5.1	Marking of fittings	07
5.2	Marking of pipes	07
6	Connection of pipes and fittings	08
6.1	Heated tool butt welding	08
6.2	Electrofusion welding	08
6.3	Flange connections	08
6.3.1	Gaskets	10
6.3.2	Tightening torques for bolts	11
7	System pressure rating	12
7.1	Maximum operating pressure of approved pipes and fittings for 175 psi	12
7.2	Maximum operating pressure of approved pipes and fittings for 200 psi	13
8	Hydraulic pressure losses	14
8.1	Pressure loss in straight pipes	14
8.2	Pressure loss in fittings	15
9	Installation of fire-fighting pipe systems	17
9.1	Trench design for buried firefighting pipes	17
9.2	Bedding material	18
9.3	Thrust blocks	18
10	Anchor	19
11	Hydrant Connection	19
12	Hydrostatic pressure test	20
12.1	Filling and checking	20
12.2	Preparation pressure test	20
12.3	Test pressure	20
12.4	Types of pressure tests	20
12.5	Pressure pre-test	21
12.6	Integrated pressure loss test	21
12.7	Main pressure test	21
13	Specification of AGRU PE 100 pipes and fittings for underground fire protection systems	22
14	Product Range 218 psi	25
15	Product Range 250 psi	65

1 Factory Mutual

1.1 Ensuring Quality, Dependability and Performance

FM global is the world’s largest commercial and industrial property insurance and risk management organisation specialising in property protection. FM Approvals certifies products and services for thousands of companies worldwide to help improve and advance property loss prevention. Globally recognized and respected, the FM APPROVED mark assures a product or service has been objectively tested and conforms to appropriate FM Approvals, national and international standards. Customers rely on FM Approvals for assurance that FM Approved products and services will perform as intended and support property loss prevention.

1.2 Benefits of FM approved products:

Tested under extreme conditions

- Reliable performance due to regular quality audits of producers
- Technical product support by local representatives
- Product approval can help manufacturers and service providers:
 - // Meet client demands
 - // Accordance to code and jurisdictional installation requirements worldwide
 - // Achieve competitive advantage, whether at home or in the global marketplace
 - // Move products to market fast on a global basis

1.3 Standard

AGRU offers a broad product range that is tested and certified for fire protection systems. The performed and approved standards for these high quality products are:

Approval standard for Polyethylene (PE) Pipe and Fittings for Underground Fire Protection Class Number 1613

Date: February 2006. EN 12201, ISO 4427, AWWA C 906

Information about installation and maintenance of FM pipe systems can be found at:

Information about installation and maintenance of private fire service mains and their appurtenances.

FM data sheet 3-10, NFPA 24

1.4 Firefighting lines

The water supply of a fire protection system is often considered as the most critical component of the system. Moving the water from it’s source to the entrance of the building, is the function of underground fire protection piping. This piping system must be extremely reliable to withstand internal and external stresses over long periods of time. PE 100-RC pipes and fittings can be welded together homogenously by heated tool butt welding or electrosocket welding. The welded joints are as strong as the pipe itself, providing a continuous leak-tight system. On the other hand PE 100-RC pipes do not corrode or incrustate. This is a key point as in case of a fire emergency valves will be opened immediately and if pipes are corroded or incrustated - particles may be flushed and clog the sprinklers inside the building.



2 Material PE 100-RC

AGRU produces FM approved pipes and fittings from high quality PE 100-RC resin material. This material is perfect suitable for fire fighting systems and has been successfully used since many years. From the easy and cost saving installation to the maintenance free and safe operation there are only positive references from both installers and operators.

The features of PE 100-RC summarized:

- Lightweight – easy and fast installation
- Flexible
// Cost saving due to less fittings are needed for installation
// No damages at seismic activities like soil settlements (e.g. earthquakes)
// High resistance against pressure surge (water hammer)
- Smooth surface
// No corrosion, less abrasion or incrustation
- Secure connection due to homogeneous welding techniques
- Environmentally friendly because 100 % recyclable
- UV resistance (with carbon black)
- Low microbial growth
- Application at a broad temperature range

Material properties of the used high-grade resins (with regression curves acc. to ISO 4427) are stated in the following table 1:

	Properties	Standard	Unit	PE 100-RC
mechanical / physical	MRS Classification	ISO 9080	N/mm ²	10
	Specific density at 23 °C	ISO 1183	g/cm ³	0,96 ²
	Melt flow rate (MFR 190/5)	ISO 1133-1	g/10min	~0,3 ¹
	MFI range			T003
	Tensile stress at yield	ISO 527	MPa	≥23
	Elongation at yield	ISO 527	%	≥9
	Elongation at break	ISO 527	%	>350 ²
	Impact strength unnotched	ISO 179	kJ/m ²	no break
	Impact strength notched (at +23 °C)	ISO 179	kJ/m ²	≥ 13 ³
	Impact strength notched (at -30 °C)	ISO 179	kJ/m ²	10
	Shore-D hardness (3 sec)	ISO 868	1	~60
	Flexural strength (3.5% flexural stress)	ISO 178	MPa	≥21
	Young's Modulus	ISO 527	MPa	≥1000
thermal	Stress cracking resistance (FNCT)	ISO 16770	h	>8760
	Heat deflection temperature HDT/B	ISO 75	°C	75
	Linear coefficient of thermal expansion	DIN 53752	K-1 × 10-4	1,8 ⁴
	Thermal conductivity (at 20 °C)	DIN 52612	W/(m×K)	~0,4
electric	Flammability	UL 94	-	94-HB
		DIN 4102	-	B2
	Volume resistivity	VDE 0303	Ω × cm	>10 ¹⁶
	Surface resistivity	VDE 0303	Ω	>10 ¹³
general	Dielectric coefficient at 1 MHz	DIN 53483	-	2,3
	Electric strength	VDE 0303	kV/mm	70
	Physiologically inert	EEC 90/128	-	yes
	UV stabiliser	-	-	Carbon black
	Color	-	-	black

Table A.1: Properties of materials used for AGRU FM approved products

Guidelines from:
1) DVS 2207-1
2) EN 12201
3) DVS 2205-1 BB1
4) DVS 2210-1

* depending on the application area and operating time

Specific material properties of PE 100 - PE 4710:

PE 4710 is a material classification by American ASTM standards. The performance of PE 100 and PE 4710 classified materials can be considered to be equal to each other. Due to the different design factor of PE 4710 and PE 100 materials, PE 100 materials can be operated with 15% higher pressure for gas and water applications. The raw materials used for AGRU FM approved products comply with PE 100 as well as PE 4710 requirements.

3 Chemical resistance

PE 100-RC pipes are chemical resistant against inorganic/organic acids, inorganic salts and media with basic character (pH>12) even up to high concentrations. Organic chemicals and the molecular chain of the PE 100-RC polymer are very similar, they are structurally related to each other. The organic media might have a swelling effect on PE 100-RC. Swelling means, that the distance between the molecular chains increases. There is a change in volume and shape due to the influence of the organic media. Swelling is a reversible process, in case that there is no contact between the organic media and the HDPE polymer, the swelling effect disappears. The organic media, which are present in foams for fire-fighting do not have a significant chemical effect on PE 100-RC.

Chemical resistance of PE 100-RC against chlorine (in chlorination processes)

Firefighting pipe systems are often applied with adding the element chlorine in order to prevent biofouling as the water remains usually stagnant.

There are three main methods of adding chlorine to the drinking water:

- Chlorination with chlorine (Cl₂ in gaseous form)
- Chlorination with sodium hypochlorite (NaOCl)
- Chlorination with chlorine dioxide (ClO₂)

Based on information of the raw material suppliers and based on case studies AGRU Austria forwards the following recommendations on the maximum permitted concentrations:

Chlorine (Cl₂)

Components (pipes, fittings, semifinished products, concrete protective liners) made of PE100 withstands chlorine with a maximum concentration of 3 mg/l (ppm) at maximum 25 °C without any significant influence on the material properties, which means, that no reduction of the expected lifetime (in comparison to the medium water) is expected.

For higher concentrations and temperatures a chemical attack has to be considered.

This recommendation is based on statements of the raw material suppliers, who are referring to case studies of teppfa (European Plastic Pipes and Fittings Association - PE pipes for distribution for drinking water; published in 2006).

Sodium hypochlorite (NaOCl)

Components (pipes, fittings, semifinished products, concrete protective liners) made of PE100 withstands chlorine (developed by the watery solution of sodium hypochlorite) with a maximum concentration of 3 mg/l (ppm) up to maximum 25 °C without any significant influence on the material properties, which means, that no reduction of the expected lifetime (in comparison to the medium water) is expected.

This recommendation is only referring to the concentration of chlorine, developed by sodium hypochlorite in water, and not to sodium hypochlorite itself, which is a very critical medium for PE100. Concerning the chlorination process with sodium hypochlorite it has to be considered, that the pH value has always to be in basic milieu (pH value >12), otherwise there is a risk of a chemical attack.

For higher concentrations and temperatures a chemical attack has to be considered.

This recommendation is based on statements of the raw material suppliers, who are referring to case studies of teppfa (European Plastic Pipes and Fittings Association - PE pipes for distribution for drinking water; published in 2006).

Chlorine dioxide (ClO₂)

Components (pipes, fittings, semifinished products, concrete protective liners) made of PE100 are not recommended for applications with chlorine dioxide (regardless to the concentration), there is a risk of an immediate chemical attack. PE100 is no material for a long term application with chlorine dioxide. The expected life time is limited to maximum 2-5 years.

4 Quality assurance

AGRU certified products by FM are produced according to ISO 9001, ISO 14001, EN 12201 and FM approval standard 1613. There are standardized inspections for all incoming raw materials as well as during the production and at the finish product before shipment. Inspection certificates according to EN 10204 can be forwarded for each item on request.

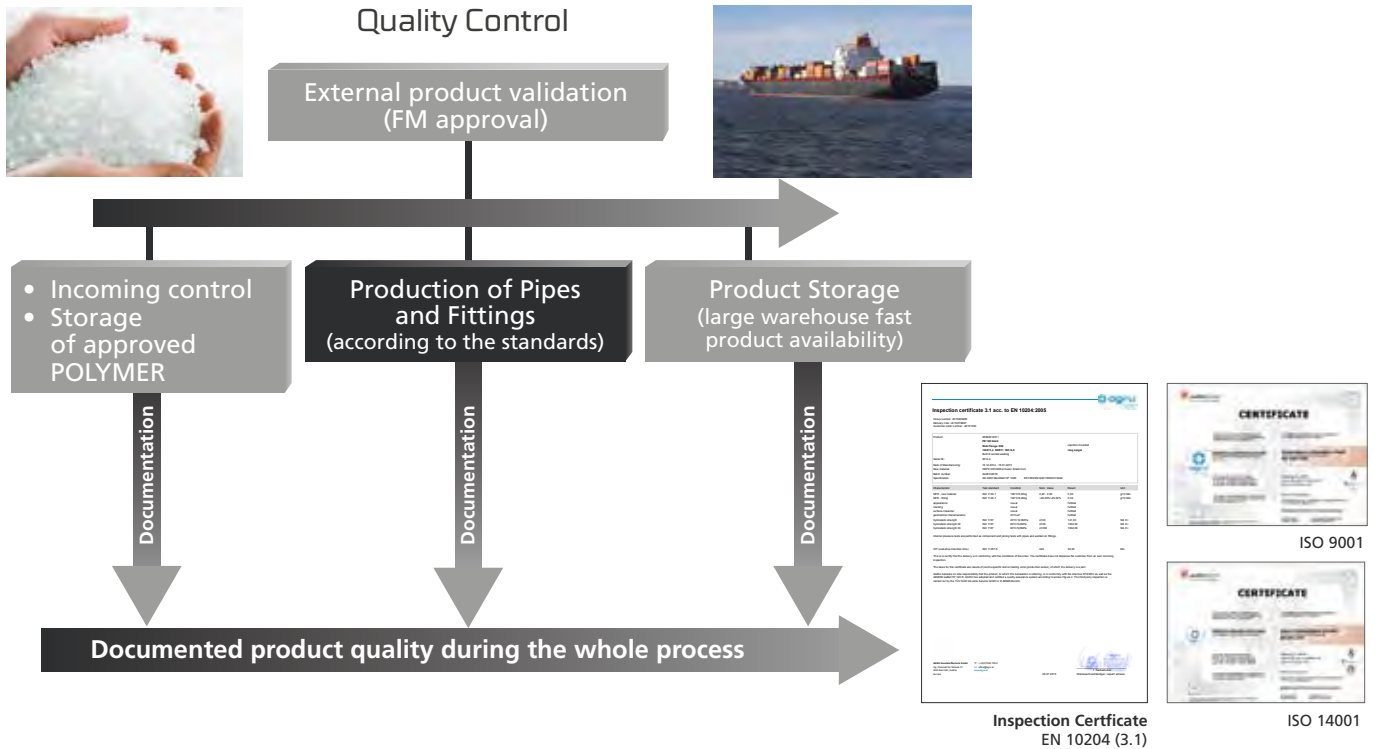

5 Marking

As required by FM approval standard 1613, all FM approved pipes and fittings shall bear the Approval Mark clearly visible. The Approval Mark shall be displayed visibly and permanently on the products.

5.1 Marking of fittings

FM approved fittings are marked according to EN 12201-3. Additionally the FM approved certification mark including the maximum operating pressure and maximum water velocity is attached on the fittings.



5.2 Marking of pipes

FM approved pipes are marked according to EN 12201-2. Additionally the FM certification mark including the maximum operating pressure is printed on the pipes.



6 Connection of FM approved pipes and fittings

AGRU pipes and fittings for firefighting systems are generally joined by heated tool butt welding, electrofusion welding or mechanically through the use of flanges. The appropriate connection technique depends on the location and the project requirements itself. Detailed guidelines for all connection techniques are available on request.

6.1 Heated tool butt welding

At the heated tool butt welding process, the joining zones of the components to be welded are aligned under pressure on the heated tool (alignment), heated up to the welding temperature with reduced pressure (heating up) and joined under pressure (joining) after removal of the heated tool (changeover).



6.2 Electrofusion welding

AGRU FM Electro-fusion fittings can be used to weld the required components using resistance wire (heating wire). The heating wire is completely embedded in the fitting. This provides a smooth inner surface and allows an easy cleaning and insertion of the pipe ends/spigots. Universal welding machines are suitable and provide the required power supply.



6.3 Flange connections:

Flange connections are used to create detachable connections between PE – PE, or as transition from PE to other materials (e.g steel, ductile iron. For example when pipes are connected to valves).



PE-PE Flange connection

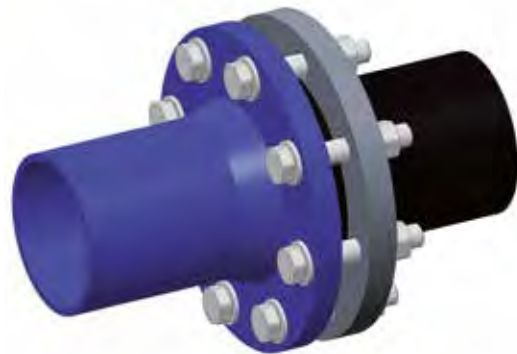

Steel-PE Flange connection

To implement valves into AGRU fire fighting pipelines, the valve must be supplied with flanges. To establish a suitable and reliable connection it is essential that the flanges of the valve and the pipeline are designed according to the same standards. The following Flange designs are available from AGRU:

DIN	Design according to EN 1092-1:2013 PN 10
ANSI	Design according to ASME B16.5:2013 class 150

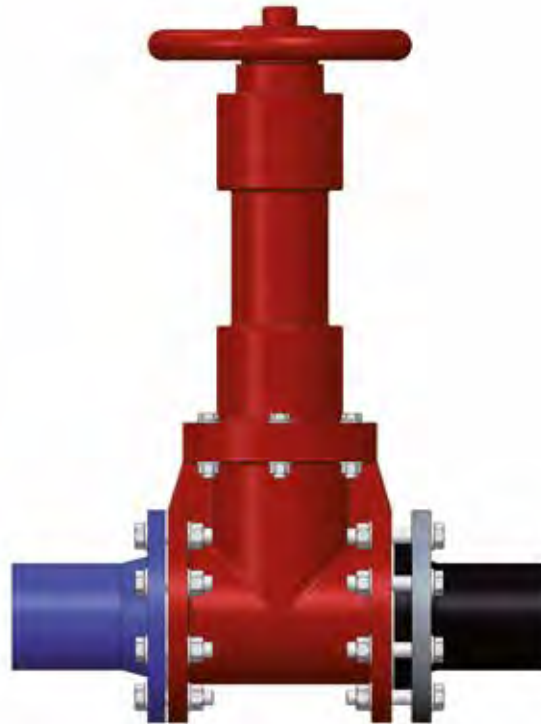

Valve connection

The recommendations below should be considered to ensure a durable and leak proof flange connection:

- It is recommended to coat the bolts for the flange connection with molybdenum sulfide grease to ensure a smooth operation, even during a long operation period.
- When choosing a seal material, consider its thermal and chemical suitability.
- The bolts shouldn't protrude further than two to three thread lengths after the nut.
- Washers have to be placed at the bolt head and also at the nut.
- Before applying the bolt initial pre-stress, the sealing faces have to be aligned coplanar to each other and fit tight to the sealing.
- Adjusting the position of the sealing faces by means of bolt pre-tensioning using a spanner is not permissible.
- The required bolt-tightening torque depends on the shape and the selected material of the seal (Shore A hardness) as well as on the friction in the screw thread and on the nut contact face (average friction coefficient of 0.15 can be expected). Please find guide values in table 2.
- The connecting bolts have to be screwed diagonally by means of a torque key (torque values see table D.8).
- The bolting torque must induce a certain amount of compressive stress on the elastomeric seal ($\geq 0,5 \text{ N/mm}^2$). Below this minimum compressive stress a leak may occur. Otherwise, an excessive compressive stress may cause damage and deformation of the seal area (seal, stub end, backing ring, etc.).
- Flange connections which are exposed to alternating stresses and heavy impacts, have to be checked within prescribed maintenance intervals and retightened if necessary.

6.3.1 Gaskets

Based on our experience we recommend the use of the following gasket types:

From **OD 63 up to OD 315** seal clean PTFE gaskets are perfect suitable for firefighting systems. Seal Clean gaskets exhibits outstanding pressure and creep resistance combined with high stability. In comparison to other gaskets, the Seal Clean provides significant less settlement because of its better creep behaviour and therefore a better leak tightness even with occurring temperature- and pressure changes.

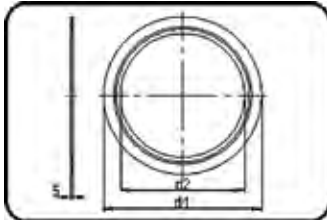

- Seal Clean Gasket
- Flange connection
- ePTFE white

Dim.	Code	Detail	OD mm	OD inch	s mm	d1 mm	d2 mm	DN mm	Weight kg
63	88.372.0063.11	63 - SDR 11 DIN	63	2	3	102	50,2	50	0.012
75	88.372.1075.11	75 - SDR 11 ANSI	75	2,5	3	117	60,5	65	0.015
90	88.372.0090.11	90 - SDR 11 DIN	90	3	3	138	73,1	80	0.028
90	88.372.1090.11	90 - SDR 11 ANSI	90	3	3	132,4	73,1	80	0.018
110	88.372.0110.11	110 - SDR 11 DIN/ANSI	110	4	3	158	88,9	100	0.035
140	88.372.0140.11	140 - SDR 11 DIN	140	5	3	188	114,1	125	0.033
160	88.372.0160.11	160 - SDR 11 DIN/ANSI	160	6	3	212	129,8	150	0.042
180	88.372.0180.11	180 - SDR 11 DIN	180	7	3	212	148	150	0.034
200	88.372.0200.11	200 - SDR 11 DIN/ANSI	200	8	3	268	162,5	200	0.067
250	88.372.0250.11	250 - SDR 11 DIN/ANSI	250	10	3	320	201,7	250	0.092
280	88.372.0280.11	280 - SDR 11 DIN	280	11	3	320	226,5	250	0.076
315	88.372.0315.11	315 - SDR 11 DIN/ANSI	315	12	3	370	253,3	315	0.172

From **OD 355 up to OD 500** profiled gaskets with steel inserts are recommended.

Detailed information is available on request.



Profiled gasket



Cross section of profiled gasket with steel insert

6.3.2 Tightening torques for bolts:

The following tightening torques are recommendations according to long term experiences:

OD MM	BOLTING TORQUE [NM]	GASKET TYPE
63	40	Seal Clean
75	55	
90	50	
110/125	45	
140	50	
160/180	80	
200/225	110	
250/280	110	
315	110	
355	70	
400	80	
450	90	
500	90	
560	100	
630	100	

Table A.2: Recommended tightening torque for bolts (for installation of the Seal Clean gasket follow the installation guideline)



Flange connection with valve

7 System pressure rating

There are 2 complete product ranges for firefighting systems available from AGRU: FM approved per approval standard 1613 for 218 psi (15 bar, SDR11), and for 250 psi (17,5 bar, SDR9). This pressure designation means maximum operating pressure for firefighting systems, at 23°C. It is calculated and tested that all the system components can handle 3,2 times of the specified pressure in case of a water hammer without any failure.

According to the EN 12201 standard, the maximum operating pressure for SDR 11 is 16 bar and for SDR 9 20 bar at 20 °C and 50 years operating time. AGRU pipes and fittings are certified for this pressure. According the test requirements of FM 1613 approval standard (short term hydrostatic strength test at 3,2x certified pressure) AGRU pipes and fittings used for firefighting systems are limited to the pressure rates as shown in **table A3 and table A4** (certified pressure) .

Recommended pressure calculation for AGRU firefighting pipes and fittings:

- As a design basis the values of the EN 12201 and ISO 4427 standard can be used (design pressure).
- The actual operating pressure should not exceed the certified pressure values in the Table 3 and Table 4 below.
- As temperature increases, a de-rating of the service pressure has to be considered. The calculated and tested pressure ratings depending on temperature and operating time are also stated in table 3 and table 4.

7.1 Maximum operating pressure of approved pipes and fittings for 218 psi

Temperature (°C)	Operating period (years)	Design pressure (SDR11) (bar)	FM 218 psi (15 bar) (bar)
10	50	19,00	15,0
20	50	16,00	15,0
23	50	15,10	15,0
30	50	13,50	13,5
38	50	12,00	12,0
40	50	11,60	11,6
50	15	9,40	9,4
60	5	7,70	7,7

Table A.3: Mop of AGRU products 218 psi for firefighting systems

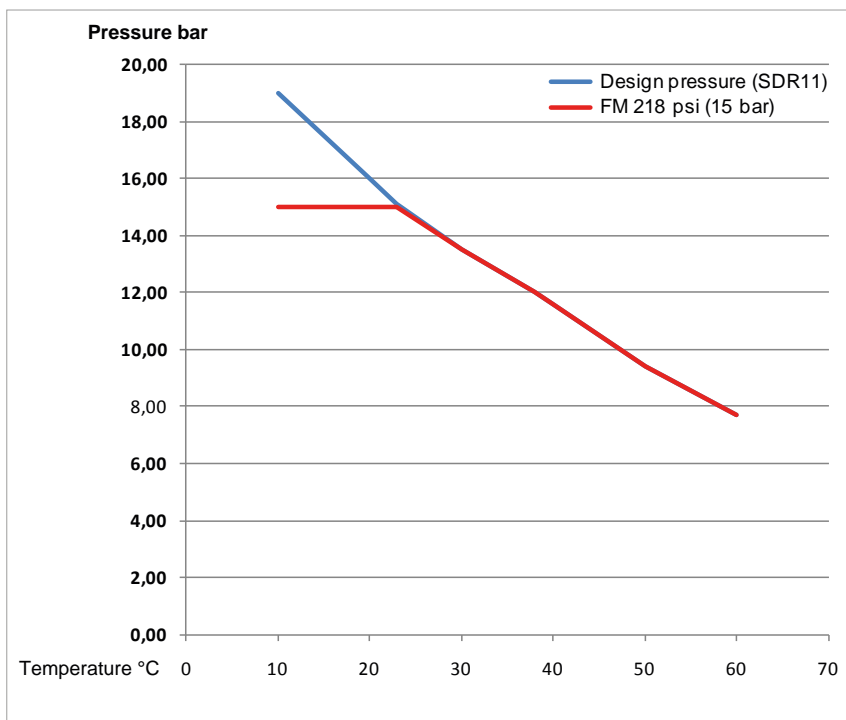

7.2 Maximum operating pressure of approved pipes and fittings for 250 psi

Temperature (°C)	Operating period (years)	Design pressure (SDR9) (bar)	FM 250 psi (17,5 bar)
10	50	23,9	17,5
20	50	20,0	17,5
23	50	19,1	17,5
30	50	17,0	17,0
40	50	14,6	14,6
45	20	13,8	13,8
50	15	11,9	11,9
60	5	9,7	9,7

Table A.4: Mop of AGRU products 250 psi for firefighting systems

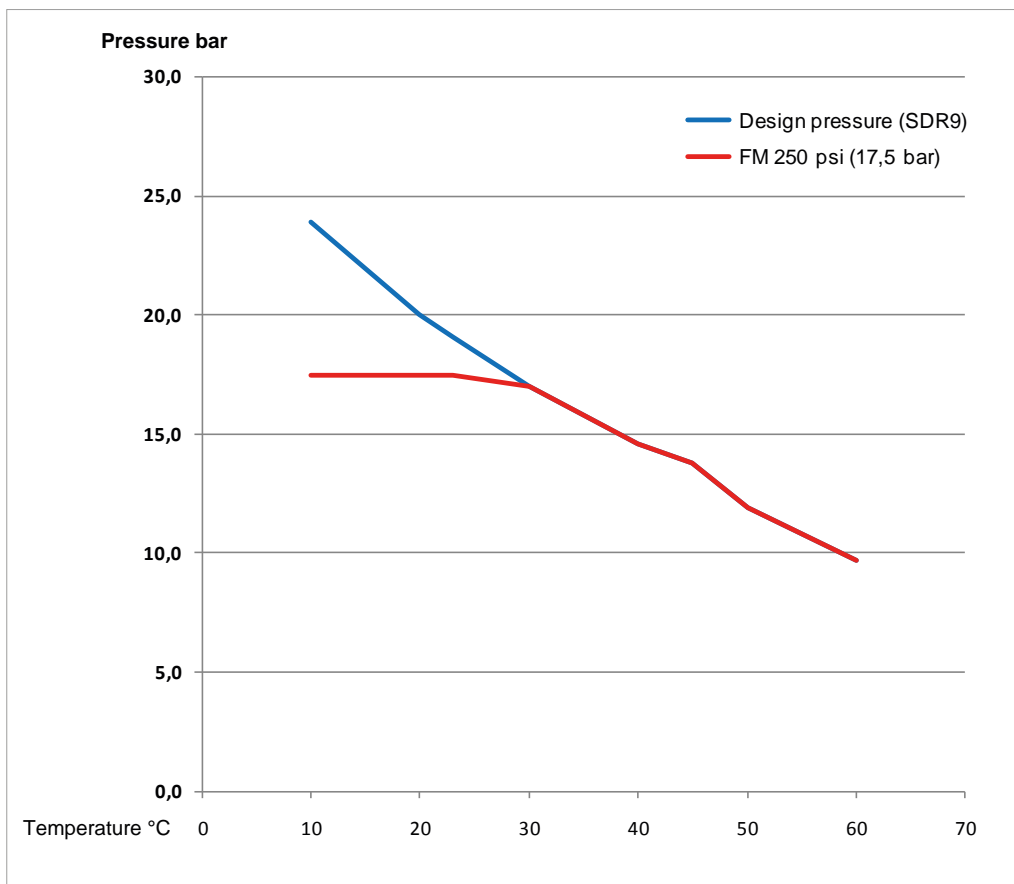

8 Hydraulic pressure losses

PE 100-RC pipes and fittings have a smooth abrasion- and incrustation resistant surface. Furthermore water does not corrode PE 100-RC pipes and fittings so that the Hazen-Williams flow coefficient "C" of 150 remains practically constant throughout the whole service lifetime. This saves energy costs (pump operating costs) and ensures a reliable and efficient performance in case of a fire emergency.

The main factors for losses are:

- Length of the piping system
- Pipe cross section
- Roughness of the pipe surface
- Geometry of fittings, mountings and finished joints or couplings
- Viscosity and density of the fluid

The whole pressure loss results from the sum of the following individual losses:

$$\Delta p_{ges} = \Delta p_R + \Delta p_{RF} + \Delta p_{RA} + \Delta p_{RV}$$

Formula 1: Total pressure loss

Δp_{ges} total pressure loss [bar]

Δp_R pressure loss in straight pipes [bar]

Δp_{RA} pressure loss in mountings [bar]

Δp_{RF} pressure loss in fittings [bar]

Δp_{RV} pressure loss in finished joints or couplings [bar]

8.1 Pressure loss in straight pipes

Pressure loss in straight pipes is inversely proportional to the pipe cross section.

$$\Delta p_R = \lambda \cdot \frac{L}{ID} \cdot \frac{\rho}{2 \cdot 10^2} \cdot v^2$$

Formula Pressure loss in straight pipes.

ID	inside diameter of pipe [mm]
L	length of piping system [m]
Δp^R	pressure loss in straight pipes [bar]
λ	pipe frictional index 0.02 (sufficient in most cases) [1]
v	flow velocity [m/s]
ρ	medium density [kg/m ³]

Pressure loss in pipes can also be calculated with the empirical Hazen-Williams equation.

$$h = \frac{10,67 \cdot q^{1,85}}{c^{1,85} \cdot d_h^{4,8655}}$$

h	head loss per unit pipe [mh20/m pipe]
c	design coefficient (PE-HD = 150)
q	flow rate [m ³ /s]
d_h	inside hydraulic diameter [m]

8.2 Pressure loss in fittings

Inside the fittings friction, deflection and detachment cause considerable pressure losses.

The resistance coefficients, used for the calculation can be taken from the following chapter.

$$\Delta p_{RF} = \zeta \cdot \frac{\rho}{2 \cdot 10^5} \cdot v^2$$

Δp_{RF} pressure loss in fittings [bar]

ζ resistance coefficient for fittings [1]

v flow velocity [m/s]

ρ medium density [kg/m³]

Resistance coefficients for fittings

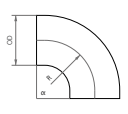
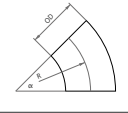
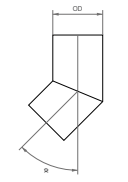
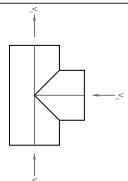
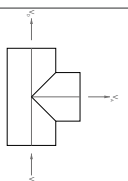
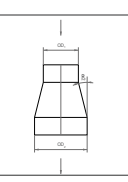
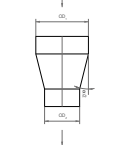
Fitting	Parameter	Resistance coefficient [1]			Flow
Bend 90°	R	ζ			
	1.0 × OD	0.51			
	1.5 × OD	0.41			
	2.0 × OD	0.34			
	4.0 × OD	0.23			
Bend 45°	R	ζ			
	1.0 × OD	0.34			
	1.5 × OD	0.27			
	2.0 × OD	0.20			
	4.0 × OD	0.15			
Elbow	α	ζ			
	90°	~ 1.20			
	45°	0.30			
	30°	0.14			
	20°	0.05			
	15°	0.05			
	10°	0.04			
Tee 90° (confluence)	V_z / V_s	ζ_z	ζ_A		
	0.0	-1.20	0.06		
	0.2	-0.40	0.20		
	0.4	0.10	0.30		
	0.6	0.50	0.40		
	0.8	0.70	0.50		
	1.0	0.90	0.60		
Tee 90° (bifurcation)	V_A / V_s	ζ_z	ζ_A		
	0.0	0.97	0.10		
	0.2	0.90	-0.10		
	0.4	0.90	-0.05		
	0.6	0.97	0.10		
	0.8	1.10	0.20		
	1.0	1.30	0.35		
Reduction (pipe extension)	OD_1 / OD_2	$4^\circ < \alpha < 8^\circ$	$\alpha < 16^\circ$	$\alpha < 24^\circ$	
	1.2	0.10	0.15	0.20	
	1.4	0.20	0.30	0.50	
	1.6	0.50	0.80	1.50	
	1.8	1.20	1.80	3.00	
	2.0	1.90	3.10	5.30	
Reduction (pipe throat)	OD_2 / OD_1	$\alpha < 4^\circ$	$\alpha < 8^\circ$	$\alpha < 20^\circ$	
	1.2	0.046	0.023	0.010	
	1.4	0.067	0.033	0.013	
	1.6	0.076	0.038	0.015	
	1.8	0.031	0.041	0.016	
	2.0	0.034	0.042	0.017	

Positive ζ -values represent a pressure drop, whereas negative ζ -values represent a pressure increase.

- V_A outgoing volume flow
- V_D continuous volume flow
- V_S total volume flow
- V_z additional volume flow

9 Installation of firefighting pipe systems

Polyethylene pipe systems should be installed according to the national requirements and laws, the manufacturer's instructions and FM Global Property Loss Prevention Data Sheets (FM data sheet 3-10: Installation and maintenance of private fire service mains and their appurtenances).

FM Approved PE pipes and fittings according to the approval standard 1613 are for underground installed use only!

9.1 Trench design for buried FM approved pipelines

The following recommendation is according to EN 805 and ÖVGW G E100. For the pipe trench construction and the installation of the pipes corresponding national and regional regulations have to be taken into account.

The following influence factors on the installation technique and –depth have to be considered:

- Depth of frost or heat penetration (local conditions)
- Flow rate, pressure and temperature of the media in the pipeline
- Insulation of the pipeline
- Traffic and soil loads
- Soil type, soil moisture and the surface condition
- Crossing lines
- Sufficient compressibility of the soil around the pipeline

A structural analysis considering all influence factors should be performed by a professional engineer before each installation. For this purpose acknowledged calculation guidelines (e.g. AWWA M55, ÖNORM B5012, ATV 127) have to be used. It has to be ensured that the soil around the pipe can be properly compacted to fix the pipe in the trench.

Installation general:

The trench depth should be excavated considering national standards. In doing so the crown of the pipe should be located underneath the depth of the frost. It is recommended to place the firewater piping at least 10cm deeper than potable water lines, because of the stagnant water. The trench bottom should be planar, stable and free of stones.

Installation without sandbed for PE 100-RC:

Soil characteristics as well as the pipe material are essential for the selection of the appropriate installation method.

In addition to the installation with a sand bed PE 100-RC pipes and fittings can be used for alternative installation techniques such as installation without sand bed or trenchless installation.

Installation without sand bed means that the excavated soil can be reused to refill the trench as long as the soil is compressible according to the current standards (e.g. ÖNORM B2538 and ÖNORM B5016). The requirements for the grain sizes in a sandbed-free installation are stated in the ÖNORM B 2538.

9.2 Bedding material

The bedding material should be suitable for the particular pipeline, i.e. it must not cause corrosion, chemical or mechanical damage. A material is suitable for the bedding if it has sufficient compressibility (e.g. sand-gravel mixture). The bedding ensures that the surrounding soil absorbs the forces caused by internal pressure and external loads.

	DN	grain size [mm]	
		round	crushed
PE 100-RC	≤ 63	0-22	
pipe	> 63	0-100	

Guidelines for the mean grain size in the embedment
(acc. to DVGW W 400-2 and ÖVGW/GRIS QS-W 405/1)

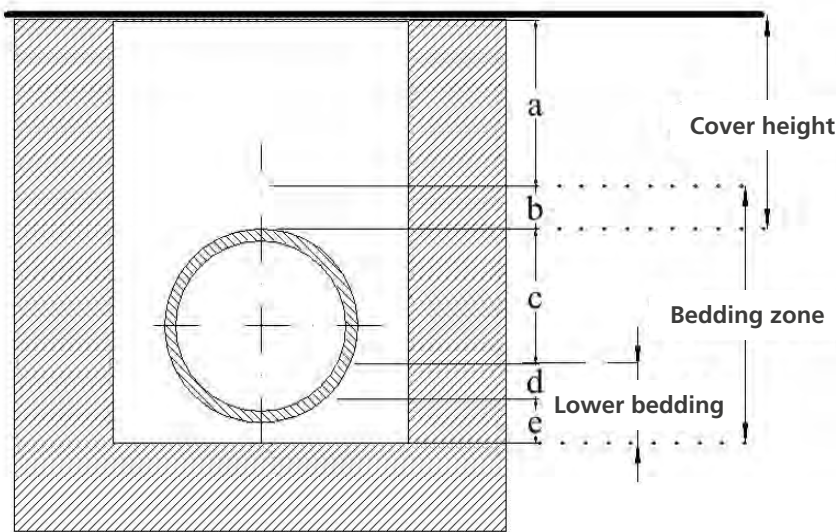

OD

Outside pipe diameter

Trench width

minimum OD + 40 cm

Cover height

minimum 80 - 100 cm (at least 2 x OD and underneath the depth of frost)

Lower bedding

minimum 10 cm, out of embedding material like sand (particle size 0...4 mm, fine quota 15%)

Bedding zone

embedding of the pipe should achieve minimum 10 cm out of the same potting material;

9.3 Thrust blocks

PE 100-RC pipes and fittings are connected homogeneously and are force-locked longitudinally. The welded joints can take the same longitudinal forces than the pipe.

If the pipeline is properly installed and the bedding material is compacted according to common standards, it is not necessary to install thrust blocks (there is no European standard which requires thrust blocks for welded PE pipelines). Due to the flexibility of the PE 100-RC materials, the thermal expansion/contraction (caused by temperature difference during the operation) is compensated by properly compressed soil around the pipe.

Long term field experiences have shown that thrust blocks aren't needed for PE 100-RC pipelines and that PE pipelines resist soil settlements. Also according to AWWA Manual M55, welded and flanged PE connections are fully restrained and do not require external joint restraints of thrust block joint anchors.

If sufficient soil conditions are not given (no proper soil stability), geotextile fabrics, and / or cement stabilized sand should be used for supporting the trench bottom .

An experienced engineer (in soils) is responsible for evaluating the soil conditions and defining the correct installation parameters to ensure perfect operation of the system.

10 Anchor

Anchors can be created under certain circumstances to limit the movement of HDPE when transitioned with other types of pipe or connected to a pump or valve. The drawing below shows steel reinforcement located near the puddle flange (fix point) to compensate the forces of expansion and contraction which un-reinforced concrete might not handle.

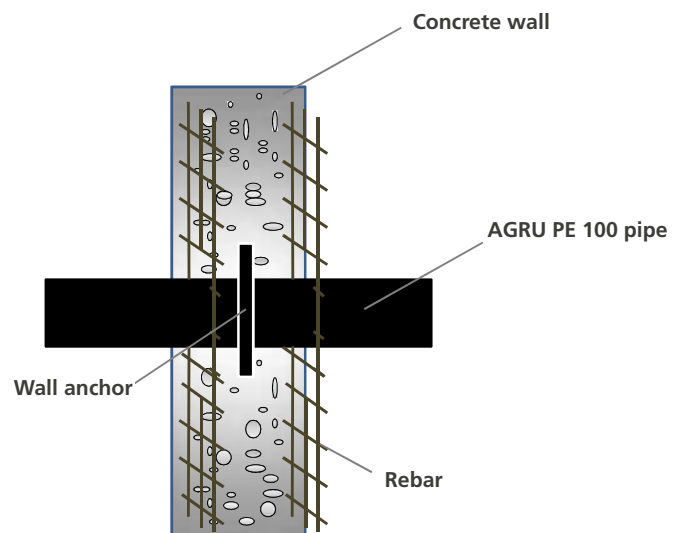

11 Hydrant Connection

Connection to a hydrant requires flanges. Due to its weight it is recommended to support the hydrant at the bottom with compressed coarse gravel or crushed stone for at least 30 cm. If the soil around the hydrant does not provide sufficient stability, it is recommended to use geotextile fabrics to stabilize the area around the hydrant bottom. This prevents soil settlements which can lead to high bending moments on the pipe and the connections.

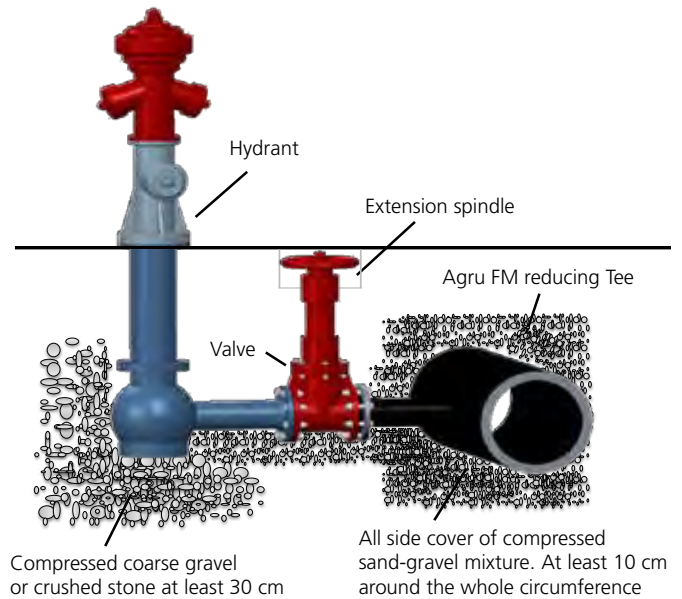

12 Guidelines for pressure test of buried water piping systems

Pressure test on the basis of EN 805 + ÖVGW W 101. Each installed water pipeline has to be tested with a water pressure test to ensure the leak tightness of the pipeline and its components. As a test medium potable water should be used.

12.1 Filling and checking

The filling of the pipeline with clean water should be conducted with open air valves and adequate venting. Calibration of the testing equipment should be carried out, before the equipment is connected to the pipe and the pressure test is started. During the test all venting devices should be closed.

12.2 Preparation pressure test

To prevent the pipeline from moving, it should be covered with enough back-fill material before the pressure test. The joints may be left uncovered. The anchors and the bearings must verifiably withstand the forces caused by the test pressure. The test should be conducted either on the complete pipeline or in sections. When the pipeline is filled, the system test pressure (STP) must be reached at the lowest part of the pipeline. At the same time the system working pressure (MDP) must be reached at least at the highest point of each testing section. Before the pressure test the pipe has to be cleaned from any kind of contamination and has to be ventilated.

12.3 Minimising the temperature influence

High temperatures (or temperature fluctuation) on the pipe surface can lead to shorter lifetime or to false pressure test results.

To reduce the temperature influence following measures are recommended during the pressure test:

- The water for the pressure test should be as cold as possible
- The exposed areas of the pipeline should be covered (shaded) during the test to prevent the pipe from heating up
- Keep the pipe wall temperatures between 2 and 20 °C and control the temperature regularly. The pressure test should be performed during moderate outside temperatures (in summer e.g. early in the morning).
- If the temperature values cannot be kept below 20 °C, the test pressure STP can be lowered as an exception to the maximum operating pressure MDP after a consultation with the planning engineer. The test section of the pipe should be continuously horizontal.

12.4 Test pressure

The system test pressure (STP) can be calculated with following formula by taking the highest system working pressure MDP into account:

By considering the pressure surge:

$$STP = MDP_c + 100 \text{ kPa}$$

By not considering the pressure surge:

$$STP = MDP_a \cdot 1,5$$

or

$$STP = MDP_a + 500 \text{ kPa}$$

The lower of the two values is valid.

STP System testing pressure

MDP_c Highest designed pressure by the planner/consultant including pressure surges

MDP_a System pressure (DP) + minimum 200 kPa for pressure surge

The pressure surge should be calculated with appropriate basic equations and assumptions of the engineer (worst case).

The testing equipment should be connected to the pipeline at its the lowest part.

For the calculation of short pipe sections and branch lines ≤ DN 80 and shorter than 100 m, the operating pressure can be assumed as system working pressure, if not otherwise specified.

12.5 Types of pressure tests

The type of pressure test is determined depending on the type of the pipe and the material. The pressure test can consist of up to three parts:

- Pressure pre-test
- Integrated pressure loss test
- Main pressure test

12.6 Pressure pre-test

The pressure pre-test is carried out to avoid incorrect test results during the main pressure test. During the pre-test following steps are carried out:

- Relaxation phase (min. 1h) after the purging and venting of the pipeline. In the process the air must not get into the test sections.
- Continuous pressure increase (within 10 min) to the system pressure (STP) and subsequent holding of the pressure (30 min). During that period the pipeline should be inspected for leakages.
- Wait the rest period (1h) without re-pressurising and measure the residual pressure. If the pressure drop is higher than 30% of the STP, then the pressure test has to stopped to search for the cause of the failure. The rerun of the test is only possible 1h after relaxation phase at the earliest.
- When the pre-test is completed successfully, the main pressure test can be started.

12.7 Integrated pressure loss test

The pressure loss test is used to determine the residual air volume in the pipeline. It allows to improve the precision of the main pressure test. During the pressure loss test the following steps are performed:

- Rapid pressure reduction (Δp : 10 – 15% of STP) by draining the water
- Measuring the volume of the drained water
- Calculating the allowable loss of water ΔV_{\max} according to the following equation:

$$\Delta V_{\max} = 1,2 \cdot V \cdot \Delta p \cdot \left(\frac{1}{E_w} + \frac{D}{e \cdot E_r} \right)$$

ΔV_{\max} allowable loss of water [l]

V volume test section [l]

Δp measured pressure drop [kPa]

E_w compressive modulus water [kPa]

D inner diameter of the pipe [m]

e wall thickness of the pipe [m]

- E_r Young's Modulus pipe wall in circumferential direction [kPa]
- 1,2 factor: allowable amount of air before the main pressure test
 - Checking if $\Delta V > \Delta V_{max}$. If ΔV is higher, the pressure test has to be stopped and repeated after the relaxation phase.

12.8 Main pressure test

The integrated pressure loss test interrupts the viscoelastic expansion of the pipe and leads to a contraction of the pipeline.

The resulting pressure rise is monitored and recorded in the period of 30 minutes. If the pressure curve doesn't drop during the monitoring period, the main pressure test is considered as passed.

A drop of the pressure curve indicates a leakage in the pipeline.

When uncertainty exists, the test duration can be extended to 90 minutes. In doing so the pressure drop cannot exceed 25 kPa, otherwise the main pressure test is considered as failed.

The repeat of the main pressure test is only possible if the complete test process (+1h relaxation phase) is repeated.

13 Specification of AGRU PE 100 pipes and fittings for underground fire protection systems

1. Scope

Requirements on FM approved Polyethylene Pipe and Fittings for underground fire protection systems.

2. Materials

High quality and virgin PE 100-RC materials that are listed by the PE 100+ association.

3. Production facility

For the production, a quality management system acc. to ISO 9001-2015 and environmental management system acc. to ISO 14001-2015 as well as an occupational health and safety management system acc. to ISO 45001 must be implemented.

4. Pipes

Pipes should be produced according to ISO 4427, EN 12201 and/or AWWA C906.

As required by FM approval standard 1613, all FM approved pipes shall bear the Approval Mark.

The Approval Mark shall be displayed visibly and permanently on the products.

5. Fittings

Fittings should be produced according to ISO 4427 and EN 12201, and certified according to EN 12201 and FM 1613.

As required by FM approval 1613, all FM approved fittings shall bear the Approval Mark.

The Approval Mark shall be displayed visibly and permanently on the products. Whenever available, injection molded fittings should be used preferably.

6. Approved Manufacturer

FM approved PE 100-RC Fittings should be provided by AGRU, FM approved PE 100-RC pipes should be provided by AGRU-FRANK.

Pipes and fittings should be produced and supplied by the same company as a complete system. Manufacturer must be ISO-9001 and + ISO 45001 certified. An inspection certificate acc. to EN 10204 (3.1) must be provided by the manufacturer on request.

7. Pressure rating

	CERTIFIED PRESSURE FOR FIRE PROTECTION SYSTEMS (Operating pressure)		DESIGN PRESSURE ACCORDING TO EN 12201
SDR 11	218 psi	15 bar	16 bar
SDR 9	250 psi	17,5 bar	20 bar

8. Installation procedures

Product information and installation procedure data must be available by the producer/supplier. This data must be released by FM approvals as well/or in accordance to FM global property loss prevention data sheet 3-10 and/or NFPA 24.

PE 100 / PE100-RC ROHRSYSTEM FM 218 PSI
PE 100 / PE100-RC PIPING SYSTEM FM 218 PSI



ROHRE
PIPES

Seite
page

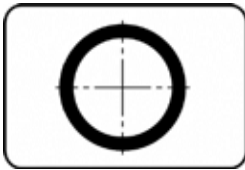

Code: 722

Rohr schwarz 12m
FM zugelassen
extrudiert
PE 100-RC schwarz

Pipe black 12m
FM approved
extruded
PE 100-RC black

167

MULTI FITTINGS
MULTI FITTINGS

Seite
page

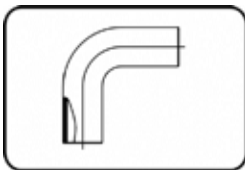

Code: 068

MULTI-Bogen 90°
lange Schenkel
formgespritzt
PE 100-RC schwarz

MULTI-Bend 90°
long spigot
injection moulded
PE 100-RC black

168

VERLÄNGERTE FITTINGS
ELONGATED FITTINGS

Seite
page

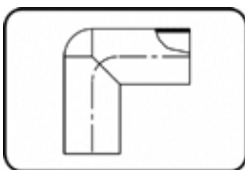

Code: 061

Winkel 90°
lange Schenkel
formgespritzt
PE 100-RC schwarz

Elbow 90°
long spigot
injection moulded
PE 100-RC black

169

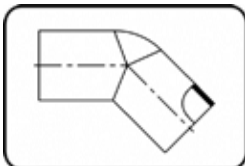

Code: 060

Winkel 45°
lange Schenkel
formgespritzt
PE 100-RC schwarz

Elbow 45°
long spigot
injection moulded
PE 100-RC black

169

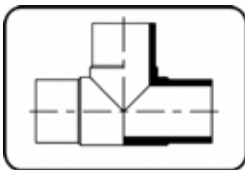

Code: 066

T-Stück
lange Schenkel
formgespritzt
PE 100-RC schwarz

Tee
long spigot
injection moulded
PE 100-RC black

170

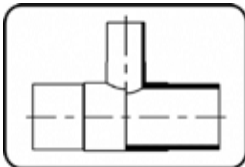

Code: 065

T-Stück reduziert
lange Schenkel
formgespritzt
PE 100-RC schwarz

Tee reduced
long spigot
injection moulded
PE 100-RC black

171

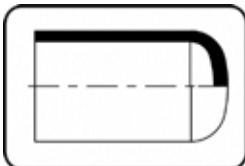

Code: 064

Endkappe
lange Schenkel
formgespritzt
PE 100-RC schwarz

End Cap
long spigot
injection moulded
PE 100-RC black

172

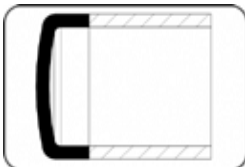

Code: 004.6

Endkappe
300mm verlängert
formgespritzt
PE 100-RC schwarz

End Cap
300mm elongated
injection moulded
PE 100-RC black

173

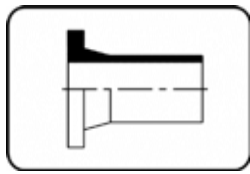

Code: 062

Vorschweissbund DIN

lange Schenkel
formgespritzt
PE 100-RC schwarz

Stub Flange DIN

long spigot
injection moulded
PE 100-RC black

173

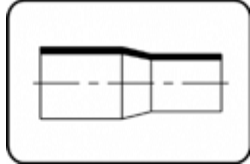

Code: 067

Reduktion konzentrisch

lange Schenkel
formgespritzt
PE 100-RC schwarz

Reducer concentric

long spigot
injection moulded
PE 100-RC black

174

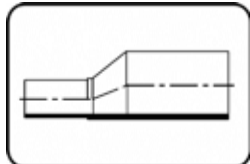

Code: 069

Reduktion exzentrisch

lange Schenkel
formgespritzt
PE 100-RC schwarz

Reducer excentric

long spigot
injection moulded
PE 100-RC black

175

ROHRBÖGEN
SWEEP BENDS

Seite
page

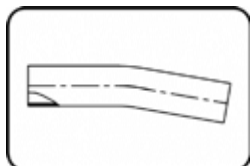

Code: 394

Rohrbogen 11°

Radius 1,5 x da
aus Rohr geformt
PE 100-RC schwarz

Sweep Bend 11°

radius 1.5 x OD
formed out of pipe
PE 100-RC black

176

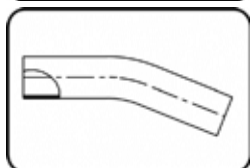

Code: 395

Rohrbogen 22°

Radius 1,5 x da
aus Rohr geformt
PE 100-RC schwarz

Sweep bend 22°

radius 1.5 x OD
formed out of pipe
PE 100-RC black

177

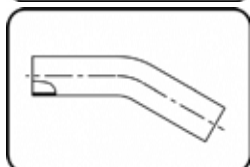

Code: 396

Rohrbogen 30°

Radius 1,5 x da
aus Rohr geformt
PE 100-RC schwarz

Sweep Bend 30°

radius 1.5 x OD
formed out of pipe
PE 100-RC black

178

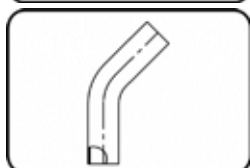

Code: 397

Rohrbogen 45°

Radius 1,5 x da
aus Rohr geformt
PE 100-RC schwarz

Sweep Bend 45°

radius 1.5 x OD
formed out of pipe
PE 100-RC black

179

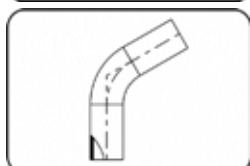

Code: 398

Rohrbogen 60°

Radius 1,5 x da
aus Rohr geformt
PE 100-RC schwarz

Sweep Bend 60°

radius 1.5 x OD
formed out of pipe
PE 100-RC black

180

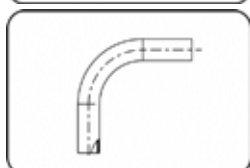

Code: 399

Rohrbogen 90°

Radius 1,5 x da
aus Rohr geformt
PE 100-RC schwarz

Sweep Bend 90°





radius 1.5 x OD
formed out of pipe
PE 100-RC black

181

Product range 218 psi

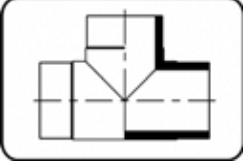
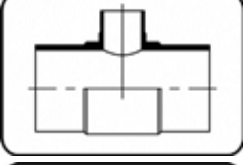
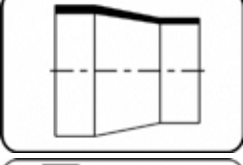
KURZSCHENKELIGE FITTINGS
FITTINGS WITH SHORT SPIGOT

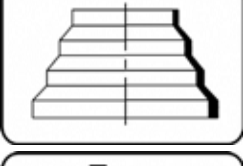
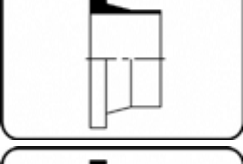
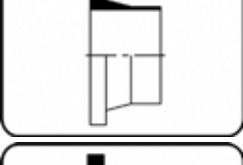
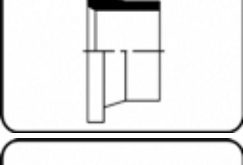
Seite
page

	Code: 001 Bogen 90° kurze Schenkel formgespritzt PE 100-RC schwarz	Bend 90° short spigot injection moulded PE 100-RC black	182
	Code: 006 T-Stück kurze Schenkel formgespritzt PE 100-RC schwarz	Tee short spigot injection moulded PE 100-RC black	183
	Code: 016 T-Stück reduziert kurze Schenkel formgespritzt PE 100-RC schwarz	Tee reduced short spigot injection moulded PE 100-RC black	184
	Code: 009 Reduktion konzentrisch kurze Schenkel formgespritzt PE 100-RC schwarz	Reducer concentric short spigot injection moulded PE 100-RC black	185
	Code: 317 Reduktion konzentrisch kurze Schenkel mechanisch gefertigt PE 100-RC schwarz	Reducer concentric short spigot machined PE 100-RC black	187
	Code: 007 Reduktion konzentrisch kurze Schenkel formgespritzt PE 100-RC schwarz	Reducer concentric short spigot injection moulded PE 100-RC black	188
	Code: 012 Vorschweissbund DIN kurze Schenkel formgespritzt PE 100-RC schwarz	Stub Flange DIN short spigot injection moulded PE 100-RC black	189
	Code: 012.1 Vorschweissbund ANSI kurze Schenkel formgespritzt PE 100-RC schwarz	Stub Flange ANSI short spigot injection moulded PE 100-RC black	190
	Code: 012.9 Armaturenband DIN für Absperrklappen formgespritzt+ausgedreht PE 100-RC schwarz	Chamfered Stub Flange DIN for butterfly valves injection moulded+chamfered PE 100-RC black	191
	Code: 004 Endkappe kurze Schenkel formgespritzt PE 100-RC schwarz	End Cap short spigot injection moulded PE 100-RC black	191

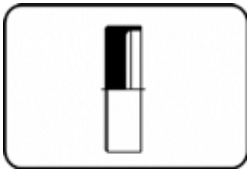

Code: 302

Endkappe
kurze Schenkel
mechanisch gefertigt
PE 100-RC schwarz

End Cap
short spigot
machined
PE 100-RC black

192

E-SCHWEISSBARE FITTINGS
ELECTRO FUSION FITTINGS

Seite
page

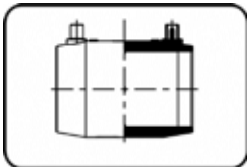

Code: 173

E-Muffe
MOP Wasser 25bar / Gas 10bar
formgespritzt
PE 100-RC schwarz

E-Coupler
MOP water 25bar/gas 10bar
injection moulded
PE 100-RC black

193

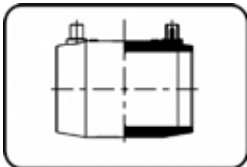

Code: 173

E-Muffe
MOP Wasser 16bar / Gas 10bar
formgespritzt
PE 100-RC schwarz

E-Coupler
MOP water 16bar/gas 10bar
injection moulded
PE 100-RC black

193



Code: 373

E-Muffe bifilar
mechanisch gefertigt
PE 100-RC schwarz

E-Coupler bifilar
machined
PE 100-RC black

194

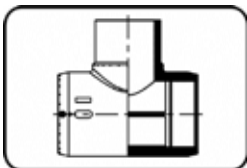

Code: 176

E-T-Stück
MOP Wasser 16bar / Gas 10bar
formgespritzt
PE 100-RC schwarz

E-Tee
MOP water 16bar/gas 10bar
injection moulded
PE 100-RC black

194

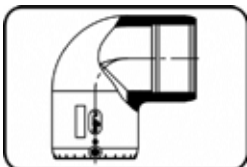

Code: 171

E-Winkel 90°
MOP Wasser 16bar / Gas 10bar
formgespritzt
PE 100-RC schwarz

E-Elbow 90°
MOP water 16bar/gas 10bar
injection moulded
PE 100-RC black

195

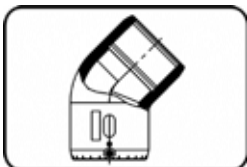

Code: 170

E-Winkel 45°
MOP Wasser 16bar / Gas 10bar
formgespritzt
PE 100-RC schwarz

E-Elbow 45°
MOP water 16bar/gas 10bar
injection moulded
PE 100-RC black

195

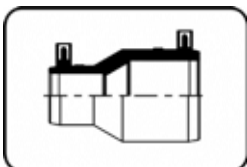

Code: 177

E-Reduktion konzentrisch
MOP Wasser 16bar / Gas 10bar
formgespritzt
PE 100-RC schwarz

E-Reducer concentric
MOP water 16bar/gas 10bar
injection moulded
PE 100-RC black

196

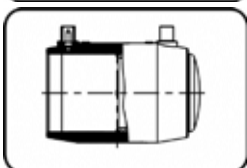

Code: 174

E-Endkappe
MOP Wasser 16bar / Gas 10bar
formgespritzt
PE 100-RC schwarz

E-End Cap
MOP water 16bar/gas 10bar
injection moulded
PE 100-RC black

197

Product range 218 psi

SCHELLEN
SADDLES

Seite
page

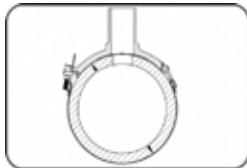

Code: 288

Stutzenschelle
MOP Wasser 16bar
formgespritzt
PE 100-RC schwarz

Spigot saddle
MOP water 16bar
injection moulded
PE 100-RC black

198



Code: 289

Stutzenschelle System Topload

mechanisch gefertigt
PE 100-RC schwarz

Spigot saddle System Topload

machined
PE 100-RC black

199

FLANSCH, ZUBEHÖR
BACKING RINGS, ACCESSORIES

Seite
page

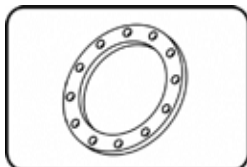

Code: 14.014

Losflansch DIN
Stahleinlage/für V-Bund
formgespritzt+gebohrt PN10/16
PP-GFK schwarz

Backing Ring DIN
steel insert/for stub flange
inj. moulded+drilled PN10/16
PP-FRP black

200

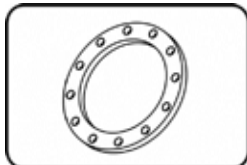

Code: 14.014

Losflansch DIN
Stahleinlage/für V-Bund
formgespritzt+gebohrt PN10
PP-GFK schwarz

Backing Ring DIN
steel insert/for stub flange
injection moulded+drilled PN10
PP-FRP black

200

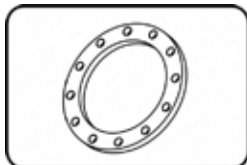

Code: 14.014.1

Losflansch DIN
Stahleinlage/für V-Bund
formgespritzt+gebohrt PN16
PP-GFK schwarz

Backing Ring DIN
steel insert/for stub flange
injection moulded+drilled PN16
PP-FRP black

201

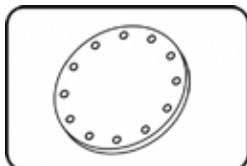

Code: 14.045

Blindflansch DIN
Stahleinlage
formgespritzt+gebohrt PN10/16
PP-GFK schwarz

Blind Flange DIN
steel insert
inj. moulded+drilled PN10/16
PP-FRP black

201

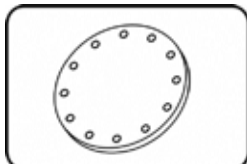

Code: 14.045

Blindflansch DIN
Stahleinlage
formgespritzt+gebohrt PN10
PP-GFK schwarz

Blind Flange DIN
steel insert
injection moulded+drilled PN10
PP-FRP black

202

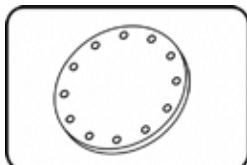

Code: 90.045

Blindflansch DIN
Stahl verzinkt
gebohrt PN10
Stahl verzinkt

Blind Flange DIN
steel galvanized
drilled PN10
steel galvanized

202

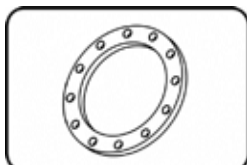

Code: 11.013

Losflansch ANSI
Stahleinlage
formgespritzt
PP-GFK grau

Backing Ring ANSI
steel insert
injection moulded
PP-FRP grey

203

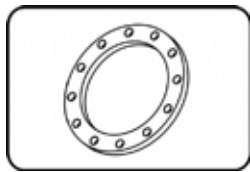

Code: 013

Losflansch ANSI

Stahleinlage
 formgespritzt
 PP-GFK schwarz

Backing Ring ANSI

steel insert
 injection moulded
 PP-FRP black

203

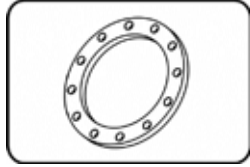

Code: 90.013

Losflansch ANSI

Stahl verzinkt
 ASME B16.5 Class 150
 Stahl verzinkt

Backing Ring ANSI

steel galvanized
 ASME B16.5 Class 150
 steel galvanized

204

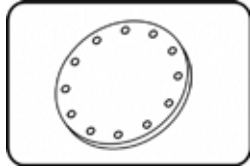

Code: 11.043

Blindflansch ANSI

Stahleinlage
 formgespritzt
 PP-GFK grau

Blind Flange ANSI

steel insert
 injection moulded
 PP-FRP grey

204

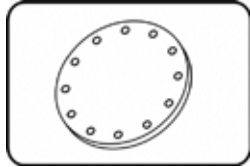

Code: 90.043

Blindflansch ANSI

Stahl verzinkt
 ASME B16.5 Class 150
 Stahl verzinkt

Blind Flange ANSI

steel galvanized
 ASME B16.5 Class 150
 steel galvanized

205

Rohr schwarz 12m

FM zugelassen

extrudiert

Pipe black 12m

FM approved

extruded

PE 100-RC schwarz

PE 100-RC black

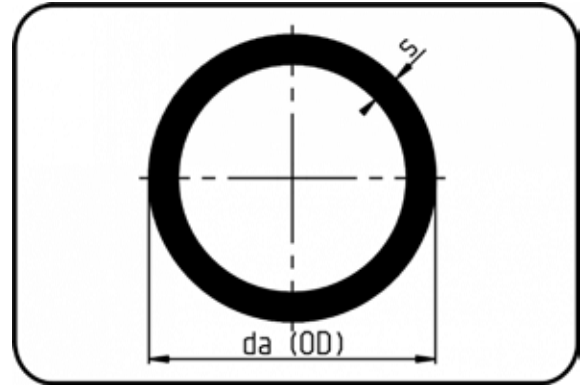

Code: 722

Dimension Dimension	Code Code	Detail Detail	da(OD) mm	s mm	Gewicht Weight
63	70.722.0063.11	63X5,8 SDR11 ISO-S5	63	5,8	1,06
75	70.722.0075.11	75X6,8 SDR11 ISO-S5	75	6,8	1,48
90	70.722.0090.11	90X8,2 SDR11 ISO-S5	90	8,2	2,13
110	70.722.0110.11	110X10,0 SDR11 ISO-S5	110	10	3,17
125	70.722.0125.11	125X11,4 SDR11 ISO-S5	125	11,4	4,12
140	70.722.0140.11	140X12,7 SDR11 ISO-S5	140	12,7	5,13
160	70.722.0160.11	160X14,6 SDR11 ISO-S5	160	14,6	6,74
180	70.722.0180.11	180X16,4 SDR11 ISO-S5	180	16,4	8,51
200	70.722.0200.11	200X18,2 SDR11 ISO-S5	200	18,2	10,50
225	70.722.0225.11	225X20,5 SDR11 ISO-S5	225	20,5	13,30
250	70.722.0250.11	250X22,7 SDR11 ISO-S5	250	22,7	16,30
280	70.722.0280.11	280X25,4 SDR11 ISO-S5	280	25,4	20,50
315	70.722.0315.11	315X28,6 SDR11 ISO-S5	315	28,6	25,90
355	70.722.0355.11	355X32,2 SDR11 ISO-S5	355	32,2	32,90
400	70.722.0400.11	400X36,3 SDR11 ISO-S5	400	36,3	41,70
450	70.722.0450.11	450X40,9 SDR11 ISO S-5	450	40,9	52,80
500	70.722.0500.11	500X45,4 SDR11 ISO S-5	500	45,4	65,20
560	70.722.0560.11	560X50,8 SDR11 ISO S-5	560	50,8	81,70
630	70.722.0630.11	630X57,2 SDR11 ISO S-5	630	57,2	103,00

MULTI-Bogen 90°

lange Schenkel

formgespritzt

Stumpf + E-Muffenschweissung

PE 100-RC schwarz

MULTI-Bend 90°

long spigot

injection moulded

Butt + E-socket-welding

PE 100-RC black

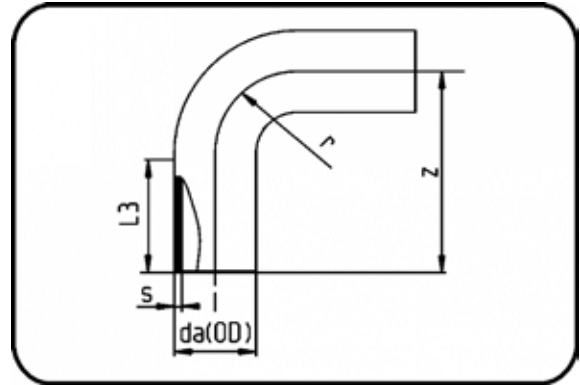

Code: 068

Dimension Dimension	Code Code	Detail Detail	da(OD) mm	s mm	z mm	r mm	L3 mm	Gewicht Weight
63	70.068.0063.11	63X5,8 SDR11 ISO S-5	63	5,8	129,5	63	66,5	0,26
75	70.068.0075.11	75X6,8 SDR11 ISO S-5	75	6,8	150	75	75	0,41
90	70.068.0090.11	90X8,2 SDR11 ISO S-5	90	8,2	168	90	76	0,69
110	70.068.0110.11	110X10,0 SDR11 ISO S-5	110	10	189	110	82	1,14
125	70.068.0125.11	125X11,4 SDR11 ISO S-5	125	11,4	218	125	92	1,68
140	70.068.0140.11	140X12,7 SDR11 ISO S-5	140	12,7	241	140	95	2,38
160	70.068.0160.11	160X14,6 SDR11 ISO S-5	160	14,6	260	160	100,5	3,32
180	70.068.0180.11	180X16,4 SDR11 ISO S-5	180	16,4	285	180	109	4,58
200	70.068.0200.11	200X18,2 SDR11 ISO S-5	200	18,2	318,5	200	118,5	6,18
225	70.068.0225.11	225X20,5 SDR11 ISO S-5	225	20,5	353	225	125	8,52

Winkel 90°

lange Schenkel

formgespritzt

Stumpf + E-Muffenschweissung

PE 100-RC schwarz

Elbow 90°

long spigot

injection moulded

Butt + E-socket-welding

PE 100-RC black

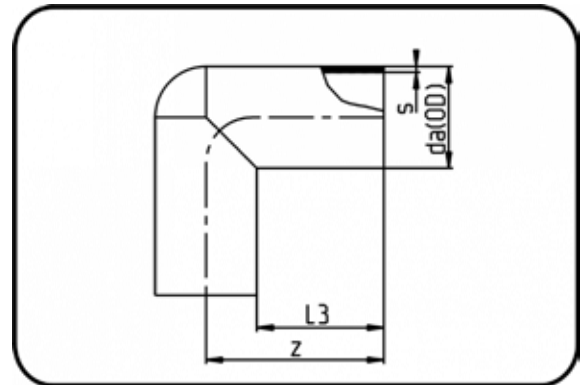

Code: 061

Dimension Dimension	Code Code	Detail Detail	da(OD) mm	s mm	z mm	L3 mm	Gewicht Weight
250	70.061.0250.11	250X22,7 SDR11 ISO S-5	250	22,7	304	175	9,44
280	70.061.0280.11	280X25,4 SDR11 ISO S-5	280	25,4	340	197	12,86
315	70.061.0315.11	315X28,6 SDR11 ISO S-5	315	28,6	370	205	18,10

Winkel 45°

lange Schenkel

formgespritzt

Stumpf + E-Muffenschweissung

PE 100-RC schwarz

Elbow 45°

long spigot

injection moulded

Butt + E-socket-welding

PE 100-RC black

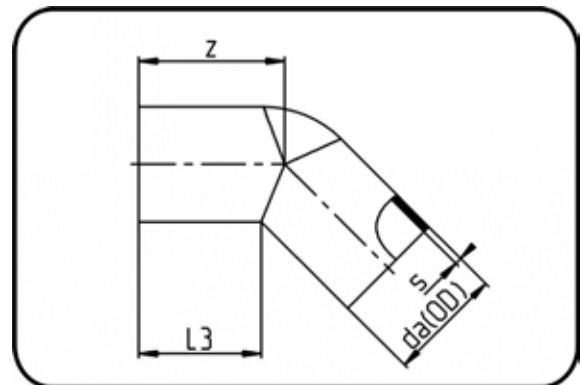

Code: 060

Dimension Dimension	Code Code	Detail Detail	da(OD) mm	s mm	z mm	L3 mm	Gewicht Weight
63	70.060.0063.11	63X5,8 SDR11 ISO S-5	63	5,8	80	65,5	0,17
75	70.060.0075.11	75X6,8 SDR11 ISO S-5	75	6,8	90	70	0,27
90	70.060.0090.11	90X8,2 SDR11 ISO S-5	90	8,2	104	82	0,44
110	70.060.0110.11	110X10,0 SDR11 ISO S-5	110	10	108	82	0,68
125	70.060.0125.11	125X11,4 SDR11 ISO S-5	125	11,4	126	99,5	1,06
140	70.060.0140.11	140X12,7 SDR11 ISO S-5	140	12,7	135	100	1,40
160	70.060.0160.11	160X14,6 SDR11 ISO S-5	160	14,6	150	116,5	2,06
180	70.060.0180.11	180X16,4 SDR11 ISO S-5	180	16,4	160	118	2,64
200	70.060.0200.11	200X18,2 SDR11 ISO S-5	200	18,2	167	122	3,58
225	70.060.0225.11	225X20,5 SDR11 ISO S-5	225	20,5	173,5	125,5	4,76
250	70.060.0250.11	250X22,7 SDR11 ISO S-5	250	22,7	217	158	7,16
280	70.060.0280.11	280X25,4 SDR11 ISO S-5	280	25,4	238	168	9,62
315	70.060.0315.11	315X28,6 SDR11 ISO S-5	315	28,6	248	176	12,90

T-Stück

lange Schenkel

formgespritzt

**Stumpf + E-
Muffenschweissung**

PE 100-RC schwarz

Tee

long spigot

injection moulded

Butt + E-socket-welding

PE 100-RC black

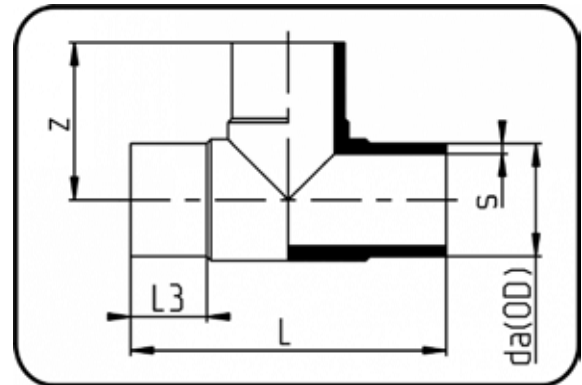

Code: 066

Dimension Dimension	Code Code	Detail Detail	da(OD) mm	s mm	z mm	L mm	L3 mm	Gewicht Weight
63	70.066.0063.11	63X5,8 SDR11 ISO S-5	63	5,8	114	226	64	0,35
75	70.066.0075.11	75X6,8 SDR11 ISO S-5	75	6,8	128	260	70	0,64
90	70.066.0090.11	90X8,2 SDR11 ISO S-5	90	8,2	143	286	79	0,97
110	70.066.0110.11	110X10,0 SDR11 ISO S-5	110	10	158	317	85	1,55
125	70.066.0125.11	125X11,4 SDR11 ISO S-5	125	11,4	177	356	91	2,21
140	70.066.0140.11	140X12,7 SDR11 ISO S-5	140	12,7	190	380	96,5	2,92
160	70.066.0160.11	160X14,6 SDR11 ISO S-5	160	14,6	202,5	405	99	4,10
180	70.066.0180.11	180X16,4 SDR11 ISO S-5	180	16,4	260	521	136	6,90
200	70.066.0200.11	200X18,2 SDR11 ISO S-5	200	18,2	245	490	112	7,92
225	70.066.0225.11	225X20,5 SDR11 ISO S-5	225	20,5	271	548	124	10,85
250	70.066.0250.11	250X22,7 SDR11 ISO S-5	250	22,7	310	622	147	15,06
280	70.066.0280.11	280X25,4 SDR11 ISO S-5	280	25,4	347	694	158	20,86
315	70.066.0315.11	315X28,6 SDR11 ISO S-5	315	28,6	375	752	168	28,46
355	70.066.0355.11	355X32,2 SDR11 ISO S-5	355	32,2	437	874	188	42,68
400	70.066.0400.11	400X36,3 SDR11 ISO S-5	400	36,3	470	940	198	56,46

T-Stück reduziert

lange Schenkel

formgespritzt

Stumpf + E-Muffenschweissung

PE 100-RC schwarz

Tee reduced

long spigot

injection moulded

Butt + E-socket-welding

PE 100-RC black

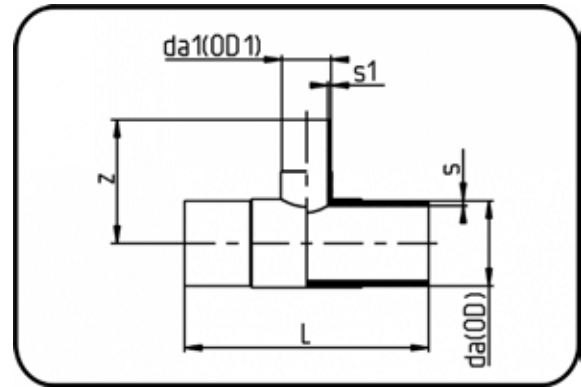

Code: 065

Dimension Dimension	Code Code	Detail Detail	da(OD) mm	da1(OD1) mm	s mm	z mm	L mm	s1 mm	Gewicht Weight
63/50	70.065.6350.11	63/50 SDR11 ISO S-5	63	50	5,8	102,5	216	4,6	0,32
75/63	70.065.7563.11	75/63 SDR11 ISO S-5	75	63	6,8	117	252	5,8	0,55
90/63	70.065.9063.11	90/63 SDR11 ISO S-5	90	63	8,2	136	266	5,8	0,76
90/75	70.065.9075.11	90/75 SDR11 ISO S-5	90	75	8,2	138	272	6,8	0,82
110/63	70.065.1163.11	110/63 SDR11 ISO S-5	110	63	10	155	305	5,8	1,24
110/75	70.065.1175.11	110/75 SDR11 ISO S-5	110	75	10	149	305	6,8	1,22
110/90	70.065.1190.11	110/90 SDR11 ISO S-5	110	90	10	155	310	8,2	1,30
125/75	70.065.1275.11	125/75 SDR11 ISO S-5	125	75	11,4	170	350	6,8	1,82
125/90	70.065.1290.11	125/90 SDR11 ISO S-5	125	90	11,4	168	332	8,2	1,70
125/110	70.065.1211.11	125/110 SDR11 ISO S-5	125	110	11,4	167	340	10	1,92
160/63	70.065.1663.11	160/63 SDR11 ISO S-5	160	63	14,6	172	340	5,8	2,62
160/75	70.065.1675.11	160/75 SDR11 ISO S-5	160	75	14,6	179	344	6,8	2,68
160/90	70.065.1690.11	160/90 SDR11 ISO S-5	160	90	14,6	177	343	8,2	2,70
160/110	70.065.1611.11	160/110 SDR11 ISO S-5	160	110	14,6	196	392	10	3,26
180/90	70.065.1890.11	180/90 SDR11 ISO S-5	180	90	16,4	200	420	8,2	4,42
180/110	70.065.1811.11	180/110 SDR11 ISO S-5	180	110	16,4	220	455	10	4,72
180/160	70.065.1816.11	180/160 SDR11 ISO S-5	180	160	16,4	204	412	14,6	4,70
200/63	70.065.2063.11	200/63 SDR11 ISO S-5	200	63	18,2	226	553	5,8	7,14
200/90	70.065.2090.11	200/90 SDR11 ISO S-5	200	90	18,2	229	550	8,2	7,16
200/110	70.065.2011.11	200/110 SDR11 ISO S-5	200	110	18,2	242	550	10	7,34
200/125	70.065.2012.11	200/125 SDR11 ISO S-5	200	125	18,2	245	550	11,4	7,34
200/160	70.065.2016.11	200/160 SDR11 ISO S-5	200	160	18,2	270	550	14,6	8,60
225/75	70.065.2275.11	225/75 SDR11 ISO S-5	225	75	20,5	226	440	6,8	6,82
225/90	70.065.2290.11	225/90 SDR11 ISO S-5	225	90	20,5	224	442	8,2	6,86
225/110	70.065.2211.11	225/110 SDR11 ISO S-5	225	110	20,5	226	448	10	6,90
225/160	70.065.2216.11	225/160 SDR11 ISO S-5	225	160	20,5	246	486	14,6	8,46
225/180	70.065.2218.11	225/180 SDR11 ISO S-5	225	180	20,5	274	546	16,4	10,04
250/75	70.065.2575.11	250/75 SDR11 ISO S-5	250	75	22,7	245	630	6,8	13,12
250/110	70.065.2511.11	250/110 SDR11 ISO S-5	250	110	22,7	245	630	10	12,96
250/160	70.065.2516.11	250/160 SDR11 ISO S-5	250	160	22,7	270	625	14,6	13,74
250/180	70.065.2518.11	250/180 SDR11 ISO S-5	250	180	22,7	268	625	16,4	13,40
250/200	70.065.2520.11	250/200 SDR11 ISO S-5	250	200	22,7	294	625	18,2	14,54
315/90	70.065.3190.11	315/90 SDR11 ISO S-5	315	90	28,6	290	545	8,2	16,02

Product range 218 psi

T-Stück reduziert

lange Schenkel

formgespritzt

Stumpf + E-Muffenschweissung

PE 100-RC schwarz

Tee reduced

long spigot

injection moulded

Butt + E-socket-welding

PE 100-RC black

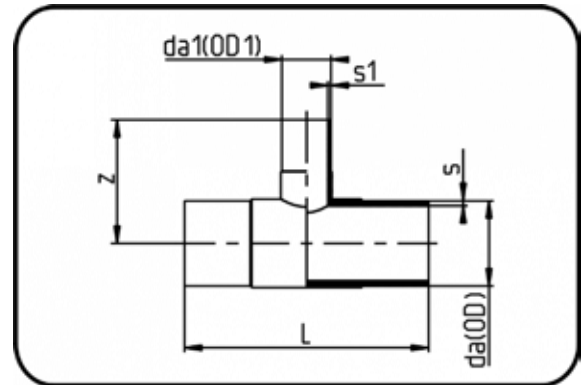

Code: 065

Dimension Dimension	Code Code	Detail Detail	da(OD) mm	da1(OD1) mm	s mm	z mm	L mm	s1 mm	Gewicht Weight
315/110	70.065.3111.11	315/110 SDR11 ISO S-5	315	110	28,6	290	546	10	15,90
315/125	70.065.3112.11	315/125 SDR11 ISO S-5	315	125	28,6	302	575	11,4	17,44
315/160	70.065.3116.11	315/160 SDR11 ISO S-5	315	160	28,6	310	575	14,6	17,52
315/180	70.065.3118.11	315/180 SDR11 ISO S-5	315	180	28,6	308	640	16,4	20,80
315/200	70.065.3120.11	315/200 SDR11 ISO S-5	315	200	28,6	326	640	18,2	21,00
315/225	70.065.3122.11	315/225 SDR11 ISO S-5	315	225	28,6	335	638	20,5	20,00
315/250	70.065.3125.11	315/250 SDR11 ISO S-5	315	250	28,6	333	670	22,7	22,84

Endkappe

lange Schenkel

formgespritzt

Stumpf + E-Muffenschweissung

PE 100-RC schwarz

End Cap

long spigot

injection moulded

Butt + E-socket-welding

PE 100-RC black

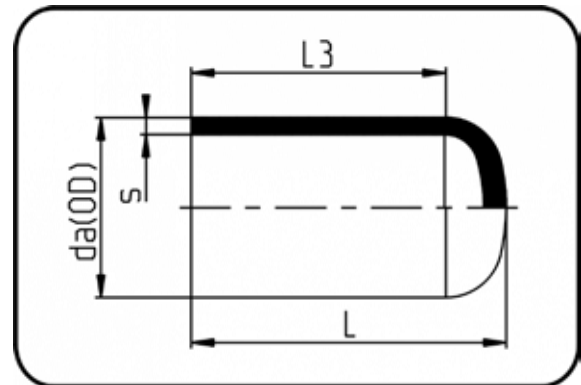

Code: 064

Dimension Dimension	Code Code	Detail Detail	da(OD) mm	s mm	L mm	L3 mm	Gewicht Weight
63	70.064.0063.11	63X5,8 SDR11 ISO S-5	63	5,8	80,5	64	0,09
75	70.064.0075.11	75X6,8 SDR11 ISO S-5	75	6,8	91	75	0,15
90	70.064.0090.11	90X8,2 SDR11 ISO S-5	90	8,2	107	84	0,25
110	70.064.0110.11	110X10,0 SDR11 ISO S-5	110	10	133	105	0,48
125	70.064.0125.11	125X11,4 SDR11 ISO S-5	125	11,4	132	100	0,59
140	70.064.0140.11	140X12,7 SDR11 ISO S-5	140	12,7	144	106	0,83
160	70.064.0160.11	160X14,6 SDR11 ISO S-5	160	14,6	165	123,5	1,20
180	70.064.0180.11	180X16,4 SDR11 ISO S-5	180	16,4	160	111	1,50
200	70.064.0200.11	200X18,2 SDR11 ISO S-5	200	18,2	181,5	117	1,96
225	70.064.0225.11	225X20,5 SDR11 ISO S-5	225	20,5	202,5	130	2,84
250	70.064.0250.11	250X22,7 SDR11 ISO S-5	250	22,7	223	160	3,91
280	70.064.0280.11	280X25,4 SDR11 ISO S-5	280	25,4	248	162	5,36
315	70.064.0315.11	315X28,6 SDR11 ISO S-5	315	28,6	269	167	7,10

Endkappe

300mm verlängert

formgespritzt

Stumpf + E-Muffenschweissung

PE 100-RC schwarz

End Cap

300mm elongated

injection moulded

Butt + E-socket-welding

PE 100-RC black

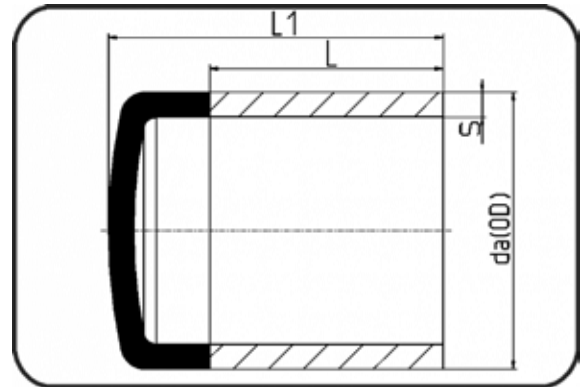

Code: 004.6

Dimension Dimension	Code Code	Detail Detail	da(OD) mm	s mm	L mm	L1 mm	Gewicht Weight
355	70.004.6355.11	355 X 32,2 SDR11 ISO S-5	355	32,2	300	420	16,23
400	70.004.6400.11	400 X 36,3 SDR11 ISO S-5	400	36,3	300	430	21,20

Vorschweissbund DIN

lange Schenkel

formgespritzt

Stumpf + E-Muffenschweissung

PE 100-RC schwarz

Stub Flange DIN

long spigot

injection moulded

Butt + E-socket-welding

PE 100-RC black

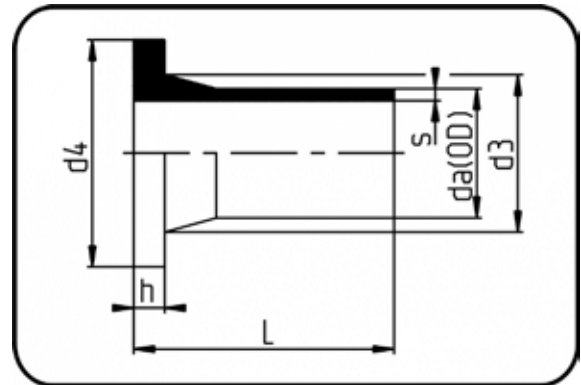

Code: 062

Dimension Dimension	Code Code	Detail Detail	da(OD) mm	s mm	L mm	d3 mm	d4 mm	h mm	Gewicht Weight
63	70.062.0063.11	63X5,8 SDR11 ISO S-5	63	5,8	122	75	102	14	0,22
75	70.062.0075.11	75X6,8 SDR11 ISO S-5	75	6,8	125	89	122	16	0,31
90	70.062.0090.11	90X8,2 SDR11 ISO S-5	90	8,2	140	105	138	17	0,45
110	70.062.0110.11	110X10,0 SDR11 ISO S-5	110	10	159	125	158	18	0,73
125	70.062.0125.11	125X11,4 SDR11 ISO S-5	125	11,4	169	132	158	25	0,89
140	70.062.0140.11	140X12,7 SDR11 ISO S-5	140	12,7	188	155	188	25	1,30
160	70.062.0160.11	160X14,6 SDR11 ISO S-5	160	14,6	200	175	212	25	1,76
180	70.062.0180.11	180X16,4 SDR11 ISO S-5	180	16,4	209	183	212	30	2,04
200	70.062.0200.11	200X18,2 SDR11 ISO S-5	200	18,2	210	232	268	32	3,22
225	70.062.0225.11	225X20,5 SDR11 ISO S-5	225	20,5	210	235	268	32	3,32
250	70.062.0250.11	250X22,7 SDR11 ISO S-5	250	22,7	204	285	320	35	4,70
280	70.062.0280.11	280X25,4 SDR11 ISO S-5	280	25,4	218	288	320	35	5,20
315	70.062.0315.11	315X28,6 SDR11 ISO S-5	315	28,6	238	335	370	35	7,58
355	70.062.0355.11	355X32,2 SDR11 ISO S-5	355	32,2	257	373	430	40	10,64
400	70.062.0400.11	400X36,3 SDR11 ISO S-5	400	36,3	274	427	482	46	14,42

Flansche finden Sie bitte unter Zubehör.
Backing Rings please see Accessories.

Reduktion konzentrisch

lange Schenkel

formgespritzt

**Stumpf + E-
Muffenschweissung**

PE 100-RC schwarz

Reducer concentric

long spigot

injection moulded

Butt + E-socket-welding

PE 100-RC black

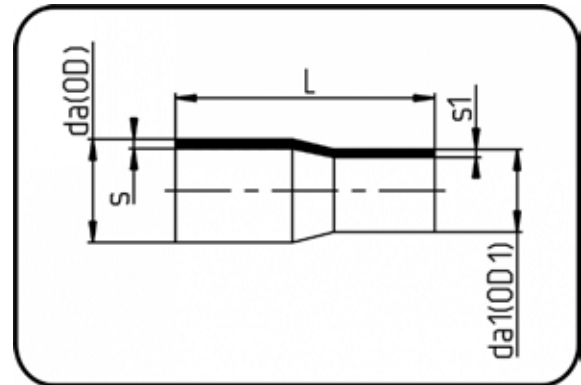

Code: 067

Dimension Dimension	Code Code	Detail Detail	da(OD) mm	da1(OD1) mm	s mm	L mm	s1 mm	Gewicht Weight
90/63	70.067.9063.11	90/63 SDR11 ISO S-5	90	63	8,2	172	5,8	0,29
110/63	70.067.1163.11	110/63 SDR11 ISO S-5	110	63	10	178	5,8	0,43
110/90	70.067.1190.11	110/90 SDR11 ISO S-5	110	90	10	177	8,2	0,50
125/63	70.067.1263.11	125/63 SDR11 ISO S-5	125	63	11,4	195	5,8	0,56
125/90	70.067.1290.11	125/90 SDR11 ISO S-5	125	90	11,4	200	8,2	0,64
125/110	70.067.1211.11	125/110 SDR11 ISO S-5	125	110	11,4	200	10	0,74
140/125	70.067.1412.11	140/125 SDR11 ISO S-5	140	125	12,7	211	11,4	0,99
160/90	70.067.1690.11	160/90 SDR11 ISO S-5	160	90	14,6	217	8,2	1,05
160/110	70.067.1611.11	160/110 SDR11 ISO S-5	160	110	14,6	225	10	1,18
160/125	70.067.1612.11	160/125 SDR11 ISO S-5	160	125	14,6	231	11,4	1,32
160/140	70.067.1614.11	160/140 SDR11 ISO S-5	160	140	14,6	229	12,7	1,36
180/125	70.067.1812.11	180/125 SDR11 ISO S-5	180	125	16,4	270	11,4	1,82
180/160	70.067.1816.11	180/160 SDR11 ISO S-5	180	160	16,4	245	14,6	1,91
200/160	70.067.2016.11	200/160 SDR11 ISO S-5	200	160	18,2	252	14,6	2,27
225/160	70.067.2216.11	225/160 SDR11 ISO S-5	225	160	20,5	262	14,6	2,76
250/160	70.067.2516.11	250/160 SDR11 ISO S-5	250	160	22,7	314	14,6	3,98
250/225	70.067.2522.11	250/225 SDR11 ISO S-5	250	225	22,7	315	20,5	4,74
280/250	70.067.2825.11	280/250 SDR11 ISO S-5	280	250	25,4	355	22,7	6,64
315/225	70.067.3122.11	315/225 SDR11 ISO S-5	315	225	28,6	375	20,5	7,84
315/250	70.067.3125.11	315/250 SDR11 ISO S-5	315	250	28,6	375	22,7	8,32

Reduktion exzentrisch

lange Schenkel

formgespritzt

**Stumpf + E-
Muffenschweissung**

PE 100-RC schwarz

Reducer excentric

long spigot

injection moulded

Butt + E-socket-welding

PE 100-RC black

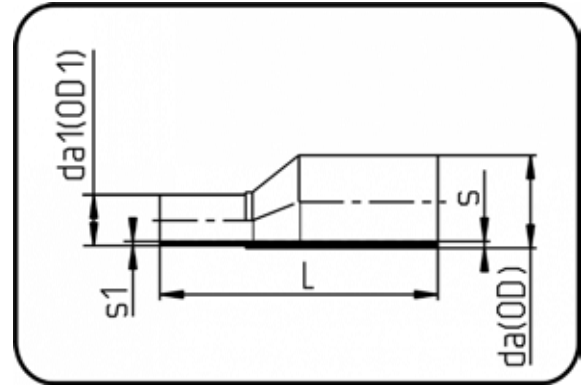

Code: 069

Dimension Dimension	Code Code	Detail Detail	da(OD) mm	da1(OD1) mm	s mm	L mm	s1 mm	Gewicht Weight
75/63	70.069.7563.11	75/63 SDR11 ISO S-5	75	63	6,8	197	5,8	0,26
90/63	70.069.9063.11	90/63 SDR11 ISO S-5	90	63	8,2	213	5,8	0,38
90/75	70.069.9075.11	90/75 SDR11 ISO S-5	90	75	8,2	214	6,8	0,40
110/63	70.069.1163.11	110/63 SDR11 ISO S-5	110	63	10	244	5,8	0,59
110/90	70.069.1190.11	110/90 SDR11 ISO S-5	110	90	10	244	8,2	0,67
125/63	70.069.1263.11	125/63 SDR11 ISO S-5	125	63	11,4	268	5,8	0,82
125/90	70.069.1290.11	125/90 SDR11 ISO S-5	125	90	11,4	265	8,2	0,91
125/110	70.069.1211.11	125/110 SDR11 ISO S-5	125	110	11,4	260	10	0,98
140/125	70.069.1412.11	140/125 SDR11 ISO S-5	140	125	12,7	283	11,4	1,32
160/90	70.069.1690.11	160/90 SDR11 ISO S-5	160	90	14,6	309	8,2	1,52
160/110	70.069.1611.11	160/110 SDR11 ISO S-5	160	110	14,6	305	10	1,66
160/125	70.069.1612.11	160/125 SDR11 ISO S-5	160	125	14,6	309	11,4	1,75
160/140	70.069.1614.11	160/140 SDR11 ISO S-5	160	140	14,6	308	12,7	1,88
180/90	70.069.1890.11	180/90 SDR11 ISO S-5	180	90	16,4	348	8,2	2,26
180/125	70.069.1812.11	180/125 SDR11 ISO S-5	180	125	16,4	345	11,4	2,46
180/160	70.069.1816.11	180/160 SDR11 ISO S-5	180	160	16,4	345	14,6	2,78
200/160	70.069.2016.11	200/160 SDR11 ISO S-5	200	160	18,2	373	14,6	3,40
200/180	70.069.2018.11	200/180 SDR11 ISO S-5	200	180	18,2	373	16,4	3,66
225/160	70.069.2216.11	225/160 SDR11 ISO S-5	225	160	20,5	402	14,6	4,37
225/180	70.069.2218.11	225/180 SDR11 ISO S-5	225	180	20,5	403	16,4	4,62
225/200	70.069.2220.11	225/200 SDR11 ISO S-5	225	200	20,5	403	18,2	4,95
250/200	70.069.2521.11	250/200 SDR11 ISO S-5	250	200	22,7	440	18,2	6,28
250/225	70.069.2522.11	250/225 SDR11 ISO S-5	250	225	22,7	440	20,5	6,84

Rohrbogen 11°

Radius 1,5 x da

aus Rohr geformt

Stumpf + E-Muffenschweissung

PE 100-RC schwarz

Sweep Bend 11°

radius 1.5 x OD

formed out of pipe

Butt + E-socket-welding

PE 100-RC black

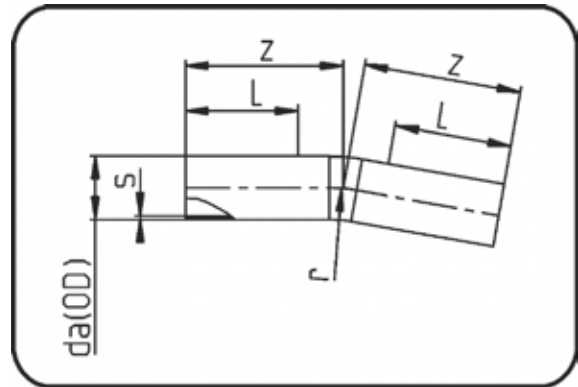

Code: 394

Dimension Dimension	Code Code	Detail Detail	da(OD) mm	s mm	z mm	r mm	L mm	Gewicht Weight
90	70.394.0090.11	90 SDR11 ISO S-5 16 bar	90	8,2	350	135	150	1,42
110	70.394.0110.11	110 SDR11 ISO S-5 16 bar	110	10	330	165	150	1,46
125	70.394.0125.11	125 SDR11 ISO S-5 16 bar	125	11,4	380	188	150	3,38
140	70.394.0140.11	140 SDR11 ISO S-5 16 bar	140	12,7	395	210	150	3,96
160	70.394.0160.11	160 SDR11 ISO S-5 16 bar	160	14,6	415	480	150	5,54
180	70.394.0180.11	180 SDR11 ISO S-5 16 bar	180	16,4	450	270	150	7,49
200	70.394.0200.11	200 SDR11 ISO S-5 16 bar	200	18,2	480	300	150	9,88
225	70.394.0225.11	225 SDR11 ISO S-5 16 bar	225	20,5	510	338	150	13,36
250	70.394.0250.11	250 SDR11 ISO S-5 16 bar	250	22,7	540	375	250	17,66
280	70.394.0280.11	280 SDR11 ISO S-5 16 bar	280	25,4	550	420	300	22,20
315	70.394.0315.11	315 SDR11 ISO S-5 16 bar	315	28,6	700	473	450	25,00
355	70.394.0355.11	355 SDR11 ISO S-5 16 bar	355	32,2	750	533	450	42,73
400	70.394.0400.11	400 SDR11 ISO S-5 16 bar	400	36,3	850	600	550	55,08
450	70.394.0450.11	450 SDR11 ISO S-5 16 bar	450	40,9	900	675	550	69,74
500	70.394.0500.11	500 SDR11 ISO S-5 16 bar	500	45,4	750	783	350	93,30
560	70.394.0560.11	560 SDR11 ISO S-5 16 bar	560	50,8	1.050	840	650	163,31
630	70.394.0630.11	630 SDR11 ISO S-5 16 bar	630	57,2	850	955	350	168,00

Rohrbogen 22°

Radius 1,5 x da

aus Rohr geformt

**Stumpf + E-
Muffenschweissung**

PE 100-RC schwarz

Sweep bend 22°

radius 1.5 x OD

formed out of pipe

Butt + E-socket-welding

PE 100-RC black

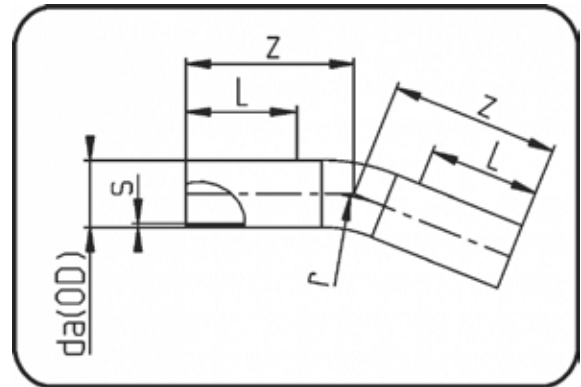

Code: 395

Dimension Dimension	Code Code	Detail Detail	da(OD) mm	s mm	z mm	r mm	L mm	Gewicht Weight
90	70.395.0090.11	90 SDR11 ISO S-5 16 bar	90	8,2	350	135	150	1,42
110	70.395.0110.11	110 SDR11 ISO S-5 16 bar	110	10	330	165	150	2,07
125	70.395.0125.11	125 SDR11 ISO S-5 16 bar	125	11,4	380	188	150	3,06
140	70.395.0140.11	140 SDR11 ISO S-5 16 bar	140	12,7	395	210	150	3,96
160	70.395.0160.11	160 SDR11 ISO S-5 16 bar	160	14,6	420	480	150	5,66
180	70.395.0180.11	180 SDR11 ISO S-5 16 bar	180	16,4	450	270	150	7,49
200	70.395.0200.11	200 SDR11 ISO S-5 16 bar	200	18,2	480	300	150	9,88
225	70.395.0225.11	225 SDR11 ISO S-5 16 bar	225	20,5	510	338	150	13,36
250	70.395.0250.11	250 SDR11 ISO S-5 16 bar	250	22,7	550	375	250	17,66
280	70.395.0280.11	280 SDR11 ISO S-5 16 bar	280	25,4	550	420	300	22,20
315	70.395.0315.11	315 SDR11 ISO S-5 16 bar	315	28,6	700	473	450	32,51
355	70.395.0355.11	355 SDR11 ISO S-5 16 bar	355	32,2	750	533	450	42,73
400	70.395.0400.11	400 SDR11 ISO S-5 16 bar	400	36,3	850	600	550	55,09
450	70.395.0450.11	450 SDR11 ISO S-5 16 bar	450	40,9	900	675	550	69,74
500	70.395.0500.11	500 SDR11 ISO S-5 16 bar	500	45,4	750	783	350	93,10
560	70.395.0560.11	560 SDR11 ISO S-5 16 bar	560	50,8	1.050	840	650	163,31
630	70.395.0630.11	630 SDR11 ISO S-5 16 bar	630	57,2	850	955	350	227,60

Rohrbogen 30°

Radius 1,5 x da

aus Rohr geformt

**Stumpf + E-
Muffenschweissung**

PE 100-RC schwarz

Sweep Bend 30°

radius 1.5 x OD

formed out of pipe

Butt + E-socket-welding

PE 100-RC black

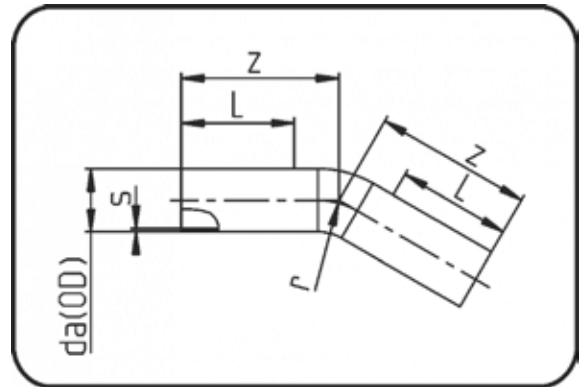

Code: 396

Dimension Dimension	Code Code	Detail Detail	da(OD) mm	s mm	z mm	r mm	L mm	Gewicht Weight
90	70.396.0090.11	90 SDR11 ISO S-5 16 bar	90	8,2	350	135	150	1,42
110	70.396.0110.11	110 SDR11 ISO S-5 16 bar	110	10	330	165	150	2,07
125	70.396.0125.11	125 SDR11 ISO S-5 16 bar	125	11,4	380	188	150	3,06
140	70.396.0140.11	140 SDR11 ISO S-5 16 bar	140	12,7	400	210	150	3,96
160	70.396.0160.11	160 SDR11 ISO S-5 16 bar	160	14,6	420	480	150	5,54
180	70.396.0180.11	180 SDR11 ISO S-5 16 bar	180	16,4	450	270	150	7,49
200	70.396.0200.11	200 SDR11 ISO S-5 16 bar	200	18,2	480	300	150	9,88
225	70.396.0225.11	225 SDR11 ISO S-5 16 bar	225	20,5	520	338	150	13,36
250	70.396.0250.11	250 SDR11 ISO S-5 16 bar	250	22,7	560	375	250	17,66
280	70.396.0280.11	280 SDR11 ISO S-5 16 bar	280	25,4	550	420	300	22,20
315	70.396.0315.11	315 SDR11 ISO S-5 16 bar	315	28,6	700	473	450	32,51
355	70.396.0355.11	355 SDR11 ISO S-5 16 bar	355	32,2	590	560	300	42,73
400	70.396.0400.11	400 SDR11 ISO S-5 16 bar	400	36,3	650	637	300	57,59
450	70.396.0450.11	450 SDR11 ISO S-5 16 bar	450	40,9	700	711	300	77,14
500	70.396.0500.11	500 SDR11 ISO S-5 16 bar	500	45,4	750	783	350	143,42
560	70.396.0560.11	560 SDR11 ISO S-5 16 bar	560	50,8	1.060	840	650	179,64
630	70.396.0630.11	630 SDR11 ISO S-5 16 bar	630	57,2	850	955	350	258,63

Rohrbogen 45°

Radius 1,5 x da

aus Rohr geformt

Stumpf + E-Muffenschweissung

PE 100-RC schwarz

Sweep Bend 45°

radius 1.5 x OD

formed out of pipe

Butt + E-socket-welding

PE 100-RC black

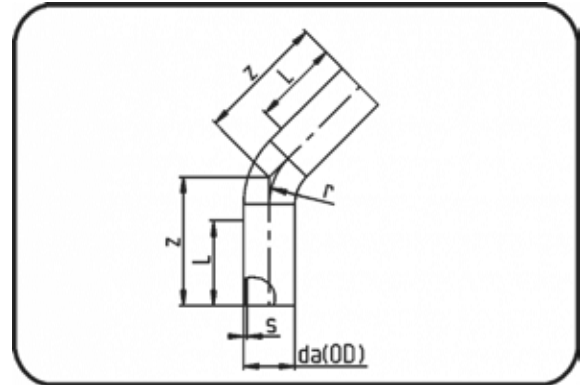

Code: 397

Dimension Dimension	Code Code	Detail Detail	da(OD) mm	s mm	z mm	r mm	L mm	Gewicht Weight
90	70.397.0090.11	90 SDR11 ISO S-5 16 bar	90	8,2	350	135	150	1,42
110	70.397.0110.11	110 SDR11 ISO S-5 16 bar	110	10	340	165	150	2,07
125	70.397.0125.11	125 SDR11 ISO S-5 16 bar	125	11,4	380	188	150	3,06
140	70.397.0140.11	140 SDR11 ISO S-5 16 bar	140	12,7	405	210	150	3,96
160	70.397.0160.11	160 SDR11 ISO S-5 16 bar	160	14,6	425	240	150	5,54
180	70.397.0180.11	180 SDR11 ISO S-5 16 bar	180	16,4	460	270	150	7,49
200	70.397.0200.11	200 SDR11 ISO S-5 16 bar	200	18,2	495	300	150	9,88
225	70.397.0225.11	225 SDR11 ISO S-5 16 bar	225	20,5	525	338	150	13,36
250	70.397.0250.11	250 SDR11 ISO S-5 16 bar	250	22,7	570	375	250	17,66
280	70.397.0280.11	280 SDR11 ISO S-5 16 bar	280	25,4	710	420	300	22,20
315	70.397.0315.11	315 SDR11 ISO S-5 16 bar	315	28,6	710	473	450	31,60
355	70.397.0355.11	355 SDR11 ISO S-5 16 bar	355	32,5	630	560	300	41,00
400	70.397.0400.11	400 SDR11 ISO S-5 16 bar	400	36,3	670	637	300	58,50
450	70.397.0450.11	450 SDR11 ISO S-5 16 bar	450	40,9	750	711	300	82,60
500	70.397.0500.11	500 SDR11 ISO S-5 16 bar	500	45,4	900	783	350	113,10
560	70.397.0560.11	560 SDR11 ISO S-5 16 bar	560	50,8	1.070	840	650	164,30
630	70.397.0630.11	630 SDR11 ISO S-5 16 bar	630	57,2	1.000	955	350	194,00

Product range 218 psi

Rohrbogen 60°

Radius 1,5 x da

aus Rohr geformt

**Stumpf + E-
Muffenschweissung**

PE 100-RC schwarz

Sweep Bend 60°

radius 1.5 x OD

formed out of pipe

Butt + E-socket-welding

PE 100-RC black

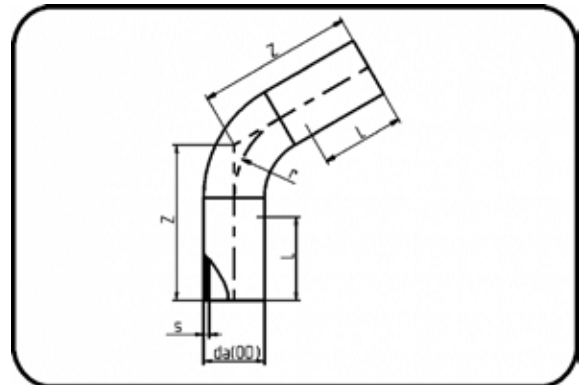

Code: 398

Dimension Dimension	Code Code	Detail Detail	da(OD) mm	s mm	z mm	r mm	L mm	Gewicht Weight
90	70.398.0090.11	90 SDR11 ISO S-5 16 bar	90	8,2	350	135	260	1,28
110	70.398.0110.11	110 SDR11 ISO S-5 16 bar	110	10	340	165	240	2,07
125	70.398.0125.11	125 SDR11 ISO S-5 16 bar	125	11,4	390	188	280	2,88
140	70.398.0140.11	140 SDR11 ISO S-5 16 bar	140	12,7	400	210	280	4,62
160	70.398.0160.11	160 SDR11 ISO S-5 16 bar	160	14,6	430	240	290	5,72
180	70.398.0180.11	180 SDR11 ISO S-5 16 bar	180	16,4	460	270	300	8,51
200	70.398.0200.11	200 SDR11 ISO S-5 16 bar	200	18,2	490	300	320	10,19
225	70.398.0225.11	225 SDR11 ISO S-5 16 bar	225	20,5	530	338	330	13,85
250	70.398.0250.11	250 SDR11 ISO S-5 16 bar	250	22,7	700	375	480	22,82
280	70.398.0280.11	280 SDR11 ISO S-5 16 bar	280	25,4	580	420	250	28,70
315	70.398.0315.11	315 SDR11 ISO S-5 16 bar	315	28,6	690	496	300	44,03
355	70.398.0355.11	355 SDR11 ISO S-5 16 bar	355	32,2	760	560	300	59,17
400	70.398.0400.11	400 SDR11 ISO S-5 16 bar	400	36,3	780	637	300	83,46
450	70.398.0450.11	450 SDR11 ISO S-5 16 bar	450	40,9	820	711	300	117,83
500	70.398.0500.11	500 SDR11 ISO S-5 16 bar	500	45,4	960	783	350	169,49
560	70.398.0560.11	560 SDR11 ISO S-5 16 bar	560	50,8	980	877	350	236,80
630	70.398.0630.11	630 SDR11 ISO S-5 16 bar	630	57,2	1.200	955	350	331,08

Rohrbogen 90 °

Radius 1,5 x da

aus Rohr geformt

**Stumpf + E-
Muffenschweissung**

PE 100-RC schwarz

Sweep Bend 90°

radius 1.5 x OD

formed out of pipe

Butt + E-socket-welding

PE 100-RC black

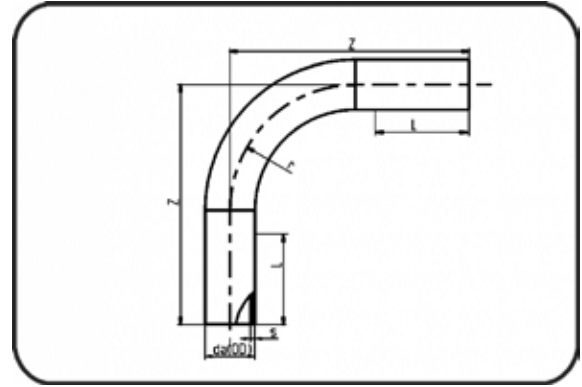

Code: 399

Dimension Dimension	Code Code	Detail Detail	da(OD) mm	s mm	z mm	r mm	L mm	Gewicht Weight
90	70.399.0090.11	90 SDR11 ISO S-5 16 bar	90	8,2	380	135	150	1,42
110	70.399.0110.11	110 SDR11 ISO S-5 16 bar	110	10	440	165	150	2,70
125	70.399.0125.11	125 SDR11 ISO S-5 16 bar	125	11,4	470	188	150	3,06
140	70.399.0140.11	140 SDR11 ISO S-5 16 bar	140	12,7	520	210	150	4,76
160	70.399.0160.11	160 SDR11 ISO S-5 16 bar	160	14,6	550	240	150	6,62
180	70.399.0180.11	180 SDR11 ISO S-5 16 bar	180	16,4	590	270	150	9,09
200	70.399.0200.11	200 SDR11 ISO S-5 16 bar	200	18,2	650	300	150	12,22
225	70.399.0225.11	225 SDR11 ISO S-5 16 bar	225	20,5	675	338	150	16,56
250	70.399.0250.11	250 SDR11 ISO S-5 16 bar	250	22,7	780	375	250	22,00
280	70.399.0280.11	280 SDR11 ISO S-5 16 bar	280	25,4	750	420	250	27,50
315	70.399.0315.11	315 SDR11 ISO S-5 16 bar	315	28,6	900	496	300	32,51
355	70.399.0355.11	355 SDR11 ISO S-5 16 bar	355	32,2	1.000	560	300	55,00
400	70.399.0400.11	400 SDR11 ISO S-5 16 bar	400	36,4	1.050	637	300	78,60
450	70.399.0450.11	450 SDR11 ISO S-5 16 bar	450	40,9	1.150	711	300	111,20
500	70.399.0500.11	500 SDR11 ISO S-5 16 bar	500	45,4	1.300	783	350	152,60
560	70.399.0560.11	560 SDR11 ISO S-5 16 bar	560	50,8	1.350	877	350	310,29
630	70.399.0630.11	630 SDR11 ISO S-5 16 bar	630	57,2	1.600	955	350	295,20

Bogen 90°

kurze Schenkel

formgespritzt

Stumpfschweissung

PE 100-RC schwarz

Bend 90°

short spigot

injection moulded

Butt-welding

PE 100-RC black

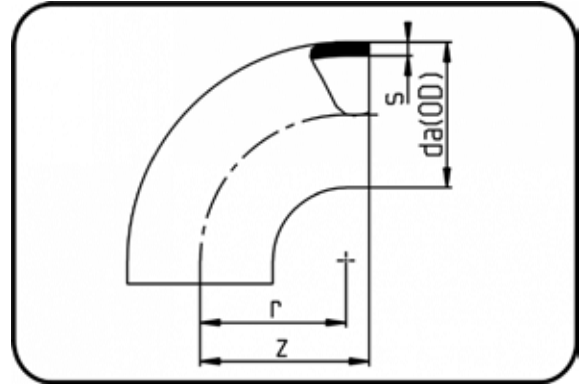

Code: 001

Dimension Dimension	Code Code	Detail Detail	da(OD) mm	s mm	z mm	r mm	Gewicht Weight
63	70.001.0063.11	63X5,8 SDR11 ISO S-5	63	5,8	70	63	0,11
75	70.001.0075.11	75X6,8 SDR11 ISO S-5	75	6,8	85	75	0,21
90	70.001.0090.11	90X8,2 SDR11 ISO S-5	90	8,2	100	90	0,37
110	70.001.0110.11	110X10,0 SDR11 ISO S-5	110	10	124	110	0,65
125	70.001.0125.11	125X11,4 SDR11 ISO S-5	125	11,4	140	125	0,93
140	70.001.0140.11	140X12,7 SDR11 ISO S-5	140	12,7	150	140	1,28
160	70.001.0160.11	160X14,6 SDR11 ISO S-5	160	14,6	180	155	2,19
180	70.001.0180.11	180X16,4 SDR11 ISO S-5	180	16,4	200	180	2,90
200	70.001.0200.11	200X18,2 SDR11 ISO S-5	200	18,2	220	200	3,68
225	70.001.0225.11	225X20,5 SDR11 ISO S-5	225	20,5	243	225	5,24
250	70.001.0250.11	250X22,7 SDR11 ISO S-5	250	22,7	290	265	8,02
280	70.001.0280.11	280X25,4 SDR11 ISO S-5	280	25,4	290	265	9,75
315	70.001.0315.11	315X28,6 SDR11 ISO S-5	315	28,6	340	300	14,36
355	70.001.0355.11	355X32,2 SDR11 ISO S-5	355	32,2	340	300	18,46
400	70.001.0400.11	400X36,3 SDR11 ISO S-5	400	36,3	345	300	23,50
450	70.001.0450.11	450X40,9 SDR11 ISO S-5	450	40,9	445	400	38,80
500	70.001.0500.11	500X45,4 SDR11 ISO S-5	500	45,4	445	400	48,34

T-Stück

kurze Schenkel

formgespritzt

Stumpfschweissung

PE 100-RC schwarz

Tee

short spigot

injection moulded

Butt-welding

PE 100-RC black

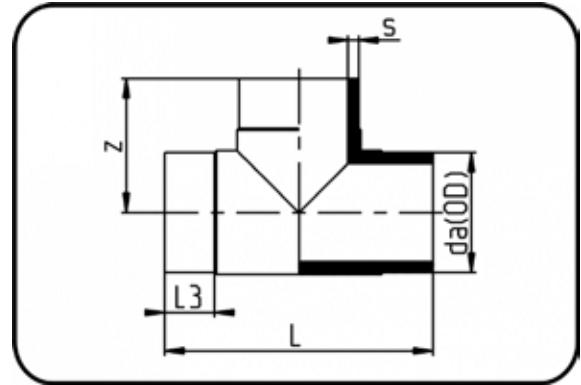

Code: 006

Dimension Dimension	Code Code	Detail Detail	da(OD) mm	s mm	z mm	L mm	L3 mm	Gewicht Weight
63	70.006.0063.11	63X5,8 SDR11 ISO S-5	63	5,8	72	144	25	0,23
75	70.006.0075.11	75X6,8 SDR11 ISO S-5	75	6,8	75	152	15	0,41
90	70.006.0090.11	90X8,2 SDR11 ISO S-5	90	8,2	105	212	38	0,70
110	70.006.0110.11	110X10,0 SDR11 ISO S-5	110	10	122	253	51	1,24
125	70.006.0125.11	125X11,4 SDR11 ISO S-5	125	11,4	140	277	52	1,88
140	70.006.0140.11	140X12,7 SDR11 ISO S-5	140	12,7	152	304	53	2,48
160	70.006.0160.11	160X14,6 SDR11 ISO S-5	160	14,6	170	340	57	3,44
180	70.006.0180.11	180X16,4 SDR11 ISO S-5	180	16,4	182,5	365	57	4,60
200	70.006.0200.11	200X18,2 SDR11 ISO S-5	200	18,2	200	400	57	6,32
225	70.006.0225.11	225X20,5 SDR11 ISO S-5	225	20,5	220	440	57	8,56
250	70.006.0250.11	250X22,7 SDR11 ISO S-5	250	22,7	235	466	72	11,16
280	70.006.0280.11	280X25,4 SDR11 ISO S-5	280	25,4	270	536	80	16,20
315	70.006.0315.11	315X28,6 SDR11 ISO S-5	315	28,6	270	540	80	19,70
355	70.006.0355.11	355X32,2 SDR11 ISO S-5	355	32,2	340	680	105	31,32
400	70.006.0400.11	400X36,3 SDR11 ISO S-5	400	36,3	350	695	103	39,30
450	70.006.0450.11	450X40,9 SDR11 ISO S-5	450	40,9	450	900	130	65,52
500	70.006.0500.11	500X45,4 SDR11 ISO S-5	500	45,4	450	900	130	73,72

T-Stück reduziert

kurze Schenkel

formgespritzt

Stumpfschweissung

PE 100-RC schwarz

Tee reduced

short spigot

injection moulded

Butt-welding

PE 100-RC black

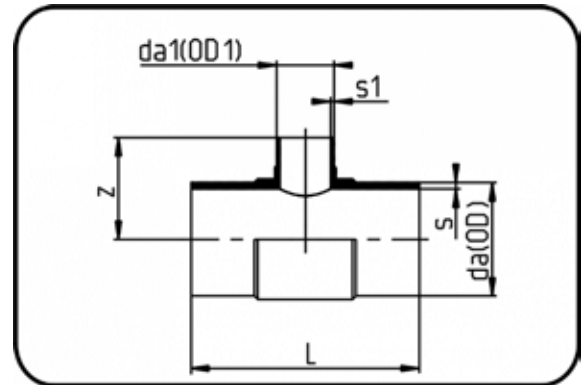

Code: 016

Dimension Dimension	Code Code	Detail Detail	da(OD) mm	da1(OD1) mm	s mm	z mm	L mm	s1 mm	Gewicht Weight
125/63	70.016.1263.11	125/63 SDR11 ISO S-5	125	63	11,4	112	275	5,8	1,42
140/63	70.016.1463.11	140/63 SDR11 ISO S-5	140	63	12,7	120	302	5,8	1,88
140/75	70.016.1475.11	140/75 SDR11 ISO S-5	140	75	12,7	130	302	6,8	1,85
140/90	70.016.1490.11	140/90 SDR11 ISO S-5	140	90	12,7	130	305	8,2	1,97
140/110	70.016.1411.11	140/110 SDR11 ISO S-5	140	110	12,7	141	305	10	2,28
160/125	70.016.1612.11	160/125 SDR11 ISO S-5	160	125	14,6	150	325	11,4	2,82
180/63	70.016.1863.11	180/63 SDR11 ISO S-5	180	63	16,4	139	358	5,8	3,16
180/75	70.016.1875.11	180/75 SDR11 ISO S-5	180	75	16,4	144	362	6,8	3,18
180/125	70.016.1812.11	180/125 SDR11 ISO S-5	180	125	16,4	166	362	11,4	3,36
225/125	70.016.2212.11	225/125 SDR11 ISO S-5	225	125	20,5	178	456	11,4	6,40

Reduktion konzentrisch

kurze Schenkel

formgespritzt

Stumpfschweissung

PE 100-RC schwarz

Reducer concentric

short spigot

injection moulded

Butt-welding

PE 100-RC black

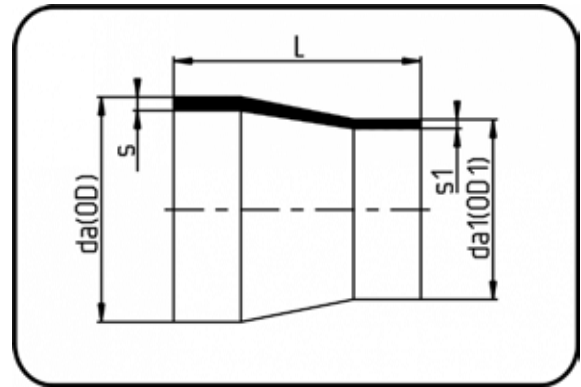

Code: 009

Dimension Dimension	Code Code	Detail Detail	da(OD) mm	da1(OD1) mm	s mm	L mm	s1 mm	Gewicht Weight
75/63	70.009.7563.11	75/63 SDR11 ISO S-5	75	63	6,8	59	5,8	0,08
90/63	70.009.9063.11	90/63 SDR11 ISO S-5	90	63	8,2	68	5,8	0,11
90/75	70.009.9075.11	90/75 SDR11 ISO S-5	90	75	8,2	68	6,8	0,13
110/50	70.009.1150.11	110/50 SDR11 ISO S-5	110	50	10	90	4,6	0,23
110/63	70.009.1163.11	110/63 SDR11 ISO S-5	110	63	10	88	5,8	0,20
110/75	70.009.1175.11	110/75 SDR11 ISO S-5	110	75	10	85	6,8	0,22
110/90	70.009.1190.11	110/90 SDR11 ISO S-5	110	90	10	85	8,2	0,22
125/63	70.009.1263.11	125/63 SDR11 ISO S-5	125	63	11,4	100	5,8	0,29
125/75	70.009.1275.11	125/75 SDR11 ISO S-5	125	75	11,4	100	6,8	0,32
125/90	70.009.1290.11	125/90 SDR11 ISO S-5	125	90	11,4	89	8,2	0,30
125/110	70.009.1211.11	125/110 SDR11 ISO S-5	125	110	11,4	89	10	0,33
140/75	70.009.1475.11	140/75 SDR11 ISO S-5	140	75	12,7	110	6,8	0,46
140/90	70.009.1490.11	140/90 SDR11 ISO S-5	140	90	12,7	110	8,2	0,47
140/110	70.009.1411.11	140/110 SDR11 ISO S-5	140	110	12,7	100	10	0,48
140/125	70.009.1412.11	140/125 SDR11 ISO S-5	140	125	12,7	92	11,4	0,45
160/90	70.009.1690.11	160/90 SDR11 ISO S-5	160	90	14,6	100	8,2	0,52
160/110	70.009.1611.11	160/110 SDR11 ISO S-5	160	110	14,6	108	10	0,64
160/125	70.009.1612.11	160/125 SDR11 ISO S-5	160	125	14,6	114	11,4	0,69
160/140	70.009.1614.11	160/140 SDR11 ISO S-5	160	140	14,6	114	12,7	0,66
180/90	70.009.1890.11	180/90 SDR11 ISO S-5	180	90	16,4	157	8,2	0,98
180/110	70.009.1811.11	180/110 SDR11 ISO S-5	180	110	16,4	157	10	1,12
180/125	70.009.1812.11	180/125 SDR11 ISO S-5	180	125	16,4	120	11,4	0,82
180/140	70.009.1814.11	180/140 SDR11 ISO S-5	180	140	16,4	136	12,7	1,03
180/160	70.009.1816.11	180/160 SDR11 ISO S-5	180	160	16,4	123	14,6	0,96
200/140	70.009.2014.11	200/140 SDR11 ISO S-5	200	140	18,2	137	12,7	1,17
200/160	70.009.2016.11	200/160 SDR11 ISO S-5	200	160	18,2	134	14,6	1,24
200/180	70.009.2018.11	200/180 SDR11 ISO S-5	200	180	18,2	137	16,4	1,36
225/140	70.009.2214.11	225/140 SDR11 ISO S-5	225	140	20,5	162	12,8	1,71
225/160	70.009.2216.11	225/160 SDR11 ISO S-5	225	160	20,5	137	14,6	1,59
225/180	70.009.2218.11	225/180 SDR11 ISO S-5	225	180	20,5	162	16,4	2,03
225/200	70.009.2220.11	225/200 SDR11 ISO S-5	225	200	20,5	162	18,2	2,01
250/160	70.009.2516.11	250/160 SDR11 ISO S-5	250	160	22,7	160	14,6	2,00
250/180	70.009.2518.11	250/180 SDR11 ISO S-5	250	180	22,7	177	16,4	2,42

Product range 218 psi

Reduktion konzentrisch

kurze Schenkel

formgespritzt

Stumpfschweissung

PE 100-RC schwarz

Reducer concentric

short spigot

injection moulded

Butt-welding

PE 100-RC black

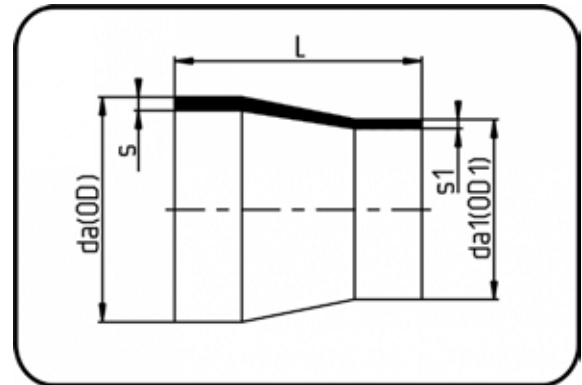

Code: 009

Dimension Dimension	Code Code	Detail Detail	da(OD) mm	da1(OD1) mm	s mm	L mm	s1 mm	Gewicht Weight
250/200	70.009.2521.11	250/200 SDR11 ISO S-5	250	200	22,7	144	18,2	2,12
250/225	70.009.2522.11	250/225 SDR11 ISO S-5	250	225	22,7	144	20,5	2,26
280/200	70.009.2820.11	280/200 SDR11 ISO S-5	280	200	25,4	202	18,2	3,74
280/225	70.009.2822.11	280/225 SDR11 ISO S-5	280	225	25,4	202	20,5	3,80
280/250	70.009.2825.11	280/250 SDR11 ISO S-5	280	250	25,4	165	22,7	3,20
315/200	70.009.3120.11	315/200 SDR11 ISO S-5	315	200	28,6	200	18,2	4,20
315/225	70.009.3122.11	315/225 SDR11 ISO S-5	315	225	28,6	209	20,5	4,56
315/250	70.009.3125.11	315/250 SDR11 ISO S-5	315	250	28,6	185	22,7	4,34
315/280	70.009.3128.11	315/280 SDR11 ISO S-5	315	280	28,6	227	25,4	5,80

Reduktion konzentrisch

kurze Schenkel

mechanisch gefertigt

Stumpfschweissung

PE 100-RC schwarz

Reducer concentric

short spigot

machined

Butt-welding

PE 100-RC black

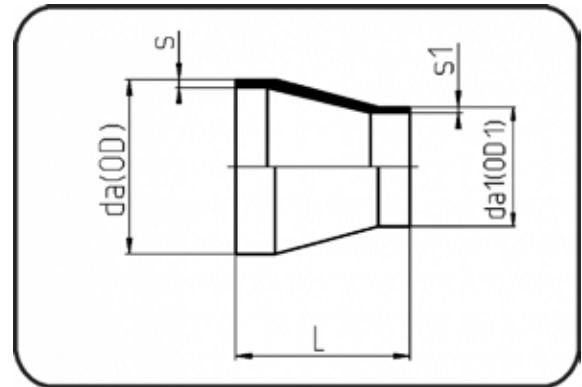

Code: 317

Dimension Dimension	Code Code	Detail Detail	da(OD) mm	da1(OD1) mm	s mm	L mm	s1 mm	Gewicht Weight
355/200	70.317.3520.11	355/200 SDR11 ISO S-5	355	200	32,2	156	18,2	5,20
355/225	70.317.3522.11	355/225 SDR11 ISO S-5	355	225	32,2	140	20,5	4,60
355/280	70.317.3528.11	355/280 SDR11 ISO S-3,2	355	280	32,2	120	25,4	5,20
355/315	70.317.3531.11	355/315 SDR11 ISO S-5	355	315	32,2	120	28,6	4,20
400/250	70.317.4025.11	400/250 SDR11 ISO S-5	400	250	36,3	150	22,7	6,40
400/315	70.317.4031.11	400/315 SDR11 ISO S-5	400	315	36,3	140	28,6	5,60
400/355	70.317.4035.11	400/355 SDR11 ISO S-5	400	355	36,3	110	32,2	4,60
500/280	70.317.5028.11	500/280 SDR11 ISO S-5	500	280	45,4	190	25,4	11,90
500/315	70.317.5031.11	500/315 SDR11 ISO S-5	500	315	45,4	170	28,6	11,40
500/355	70.317.5035.11	500/355 SDR11 ISO S-5	500	355	45,4	150	32,2	10,00
500/400	70.317.5040.11	500/400 SDR11 ISO S-5	500	400	45,4	140	36,3	9,60
500/450	70.317.5045.11	500/450 SDR11 ISO S-5	500	450	45,4	120	40,9	8,30
560/225	70.317.5622.11	560/225 SDR11 ISO S-5	560	225	50,8	240	20,5	10,50
560/500	70.317.5650.11	560/500 SDR11 ISO S-5	560	500	50,8	130	45,4	11,00
630/315	70.317.6331.11	630/315 SDR11 ISO S-5	630	315	57,2	240	28,6	19,00
630/400	70.317.6340.11	630/400 SDR11 ISO S-5	630	400	57,2	190	36,3	20,20
630/450	70.317.6345.11	630/450 SDR11 ISO S-5	630	450	57,2	170	40,9	20,20
630/500	70.317.6350.11	630/500 SDR11 ISO S-5	630	500	57,2	150	45,4	17,50
630/560	70.317.6356.11	630/560 SDR11 ISO S-5	630	560	57,2	130	50,8	14,80

Reduktion konzentrisch

kurze Schenkel

formgespritzt

Stumpfschweissung

PE 100-RC schwarz

Reducer concentric

short spigot

injection moulded

Butt-welding

PE 100-RC black

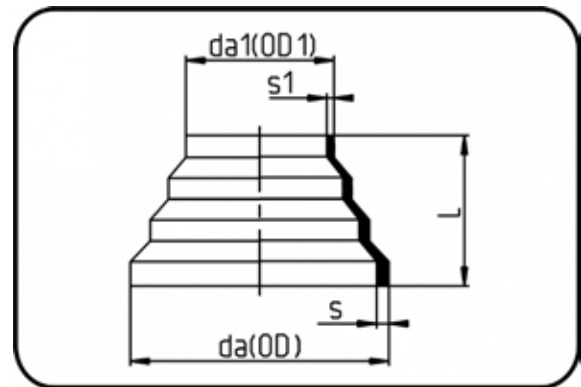

Code: 007

Dimension Dimension	Code Code	Detail Detail	da(OD) mm	da1(OD1) mm	s mm	L mm	s1 mm	Gewicht Weight
110/63	70.007.1163.11	110/63 SDR11 ISO S-5	110	63	10	62	5,8	0,14
125/75	70.007.1275.11	125/75 SDR11 ISO S-5	125	75	11,4	72	6,8	0,23
160/110	70.007.1611.11	160/110 SDR11 ISO S-5	160	110	14,6	83	10	0,43
225/160	70.007.2216.11	225/160 SDR11 ISO S-5	225	160	20,5	90	14,6	1,02
315/225	70.007.3122.11	315/225 SDR11 ISO S-5	315	225	28,6	130	20,5	2,68
450/315	70.007.4531.11	450/315 SDR11 ISO S-5	450	315	40,9	181	28,6	7,82

Vorschweissbund DIN

kurze Schenkel

formgespritzt

Stumpfschweissung

PE 100-RC schwarz

Stub Flange DIN

short spigot

injection moulded

Butt-welding

PE 100-RC black

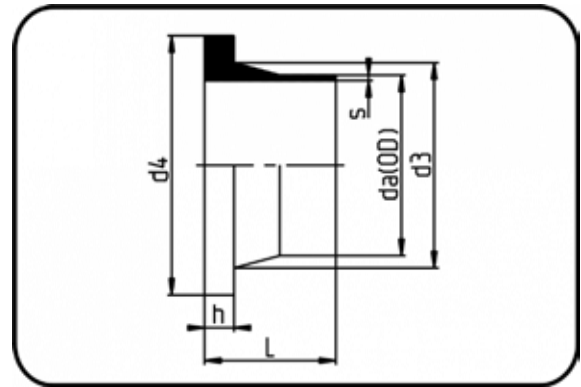

Code: 012

Dimension Dimension	Code Code	Detail Detail	da(OD) mm	s mm	L mm	d3 mm	d4 mm	h mm	Gewicht Weight
63	70.012.0063.11	63X5,8 SDR11 ISO S-5	63	5,8	50	75	102	14	0,13
75	70.012.0075.11	75X6,8 SDR11 ISO S-5	75	6,8	50,5	89	122	16	0,20
90	70.012.0090.11	90X8,2 SDR11 ISO S-5	90	8,2	80	105	138	17	0,34
110	70.012.0110.11	110X10,0 SDR11 ISO S-5	110	10	80	125	158	18	0,46
125	70.012.0125.11	125X11,4 SDR11 ISO S-5	125	11,4	80	132	158	25	0,51
140	70.012.0140.11	140X12,7 SDR11 ISO S-5	140	12,7	92	155	188	25	0,82
160	70.012.0160.11	160X14,6 SDR11 ISO S-5	160	14,6	92	175	212	25	1,03
180	70.012.0180.11	180X16,4 SDR11 ISO S-5	180	16,4	93	183	212	30	1,06
200	70.012.0200.11	200X18,2 SDR11 ISO S-5	200	18,2	114	232	268	32	2,18
225	70.012.0225.11	225X20,5 SDR11 ISO S-5	225	20,5	113	235	268	32	2,10
250	70.012.0250.11	250X22,7 SDR11 ISO S-5	250	22,7	130	285	320	35	3,56
280	70.012.0280.11	280X25,4 SDR11 ISO S-5	280	25,4	128	288	320	35	3,42
315	70.012.0315.11	315X28,6 SDR11 ISO S-5	315	28,6	136	335	370	35	5,00
355	70.012.0355.11	355X32,2 SDR11 ISO S-5	355	32,2	150	373	430	40	6,88
400	70.012.0400.11	400X36,3 SDR11 ISO S-5	400	36,3	155	427	482	46	9,04
450	70.012.0450.11	450X40,9 SDR11 ISO S-5	450	40,9	166	514	585	60	16,22
500	70.012.0500.11	500X45,4 SDR11 ISO S-5	500	45,4	175	530	585	60	15,76
560	70.012.0560.11	560X50,8 SDR11 ISO S-5	560	50,8	180	615	685	60	22,78
630	70.012.0630.11	630X57,2 SDR11 ISO S-5	630	57,2	175	642	685	60	21,84

Flansche finden Sie bitte unter Zubehör.

Backing Rings please see Accessories.

Vorschweissbund ANSI

kurze Schenkel

formgespritzt

Stumpfschweissung

PE 100-RC schwarz

Stub Flange ANSI

short spigot

injection moulded

Butt-welding

PE 100-RC black

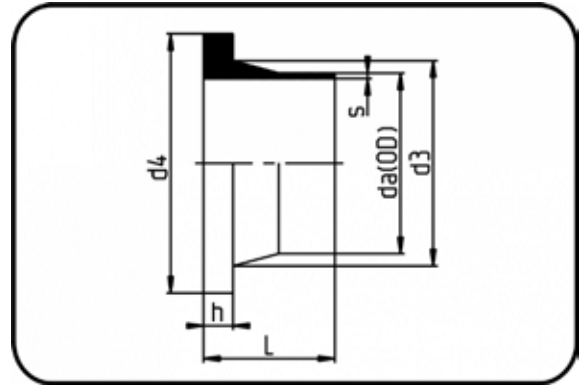

Code: 012.1

Dimension Dimension	Code Code	Detail Detail	da(OD) mm	s mm	L mm	d3 mm	d4 mm	h mm	Gewicht Weight
63	70.012.1063.11	63X5,8 SDR11 ISO S-5	63	5,8	50	75	100,4	14	0,13
75	70.012.1075.11	75X6,8 SDR11 ISO S-5	75	6,8	50,5	89	117	16	0,19
90	70.012.1090.11	90X8,2 SDR11 ISO S-5	90	8,2	80	105	132,4	17	0,32
110	70.012.1110.11	110X10,0 SDR11 ISO S-5	110	10	80	125	158	18	0,47
125	70.012.1125.11	125X11,4 SDR11 ISO S-5	125	11,4	80	132	158	25	0,52
160	70.012.1160.11	160X14,6 SDR11 ISO S-5	160	14,6	92	175	212	25	1,02
200	70.012.1200.11	200X18,2 SDR11 ISO S-5	200	18,2	114	232	268	32	2,18
225	70.012.1225.11	225X20,5 SDR11 ISO S-5	225	20,5	113	235	268	32	2,08
250	70.012.1250.11	250X22,7 SDR11 ISO S-5	250	22,7	130	285	320	35	3,56
315	70.012.1315.11	315X28,6 SDR11 ISO S-5	315	28,6	136	335	370	35	5,00
355	70.012.1355.11	355X32,2 SDR11 ISO S-5	355	32,2	150	373	430	40	7,00
400	70.012.1400.11	400X36,3 SDR11 ISO S-5	400	36,3	155	427	482	46	9,04
450	70.012.1450.11	450X40,9 SDR11 ISO S-5	450	40,9	166	514	585	60	14,20
500	70.012.1500.11	500X45,4 SDR11 ISO S-5	500	45,4	175	530	585	60	15,48
560	70.012.1560.11	560X50,8 SDR11 ISO S-5	560	50,8	180	615	655	60	20,80
630	70.012.1630.11	630X57,2 SDR11 ISO S-5	630	57,2	175	642	685	60	22,10

Flansche finden Sie bitte unter Zubehör.

Backing Rings please see Accessories.

Armaturenbund DIN

für Absperrklappen

formgespritzt+ausgedreht

Stumpfschweissung

PE 100-RC schwarz

**Chamfered Stub Flange
DIN**

for butterfly valves

injection moulded+chamfered

Butt-welding

PE 100-RC black

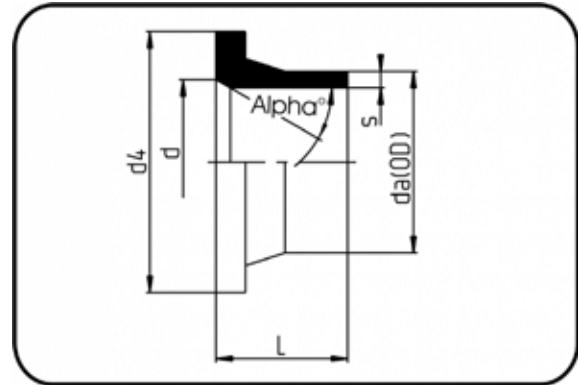

Code: 012.9

Dimension Dimension	Code Code	Detail Detail	da(OD) mm	s mm	L mm	d mm	d4 mm	alph [°]	Gewicht Weight
90	70.012.9090.11	90X8,2 SDR11 ISO S-5	90	8,2	80	80	138	30	0,33
110	70.012.9110.11	110X10,0 SDR11 ISO S-5	110	10	80	100	158	30	0,44
140	70.012.9140.11	140X12,7 SDR11 ISO S-5	140	12,7	92	125	188	30	0,77
160	70.012.9160.11	160X14,6 SDR11 ISO S-5	160	14,6	92	150	212	30	0,98
180	70.012.9180.11	180X16,4 SDR11 ISO S-5	180	16,4	93	150	212	30	1,04
200	70.012.9200.11	200X18,2 SDR11 ISO S-5	200	18,2	114	210	268	30	1,88
225	70.012.9225.11	225X20,5 SDR11 ISO S-5	225	20,5	113	210	268	30	1,94
250	70.012.9250.11	250X22,7 SDR11 ISO S-5	250	22,7	130	255	320	25	3,06
315	70.012.9315.11	315X28,6 SDR11 ISO S-5	315	28,6	136	301	370	30	4,40
355	70.012.9355.11	355X32,2 SDR11 ISO S-5	355	32,2	150	338	430	30	6,20
400	70.012.9400.11	400X36,3 SDR11 ISO S-5	400	36,3	155	378	482	30	8,40
450	70.012.9450.11	450X40,9 SDR11 ISO S-5	450	40,9	166	440	585	25	14,20
500	70.012.9500.11	500X45,4 SDR11 ISO S-5	500	45,4	175	480	585	25	13,60

Flansche finden Sie bitte unter Zubehör.

Backing Rings please see Accessories.

Endkappe

kurze Schenkel

formgespritzt

Stumpfschweissung

PE 100-RC schwarz

End Cap

short spigot

injection moulded

Butt-welding

PE 100-RC black

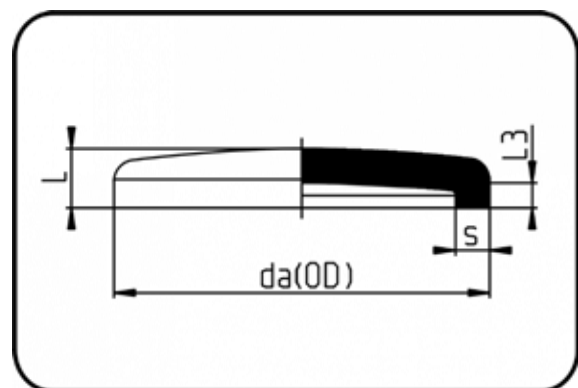

Code: 004

Dimension Dimension	Code Code	Detail Detail	da(OD) mm	s mm	L mm	L3 mm	Gewicht Weight
450	70.004.0450.11	450 X 40,9 SDR11 ISO S-5	450	40,9	140	64	11,55
500	70.004.0500.11	500 X 45,4 SDR11 ISO S-5	500	45,4	148	65	14,80

Endkappe

kurze Schenkel

mechanisch gefertigt

Stumpfschweissung

PE 100-RC schwarz

End Cap

short spigot

machined

Butt-welding

PE 100-RC black

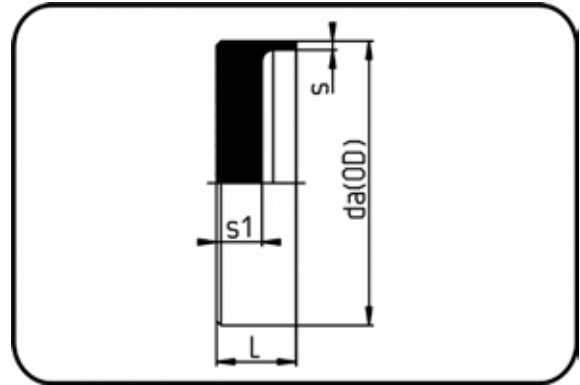

Code: 302

Dimension Dimension	Code Code	Detail Detail	da(OD) mm	s mm	L mm	s1 mm	Gewicht Weight
560	70.302.0560.11	560 X 50,8 SDR11 ISO S-5	560	50,8	120	93	23,00
630	70.302.0630.11	630 X 57,2 SDR11 ISO S-5	630	57,2	133	103	29,40

E-Muffe

MOP Wasser 25bar / Gas 10bar
MOP Wasser ÖVGW 16bar

formgespritzt

Heizwendel-Schweissung

PE 100-RC schwarz

E-Coupler

MOP water 25bar/gas 10bar
MOP water ÖVGW 16bar

injection moulded

Electro-fusion

PE 100-RC black

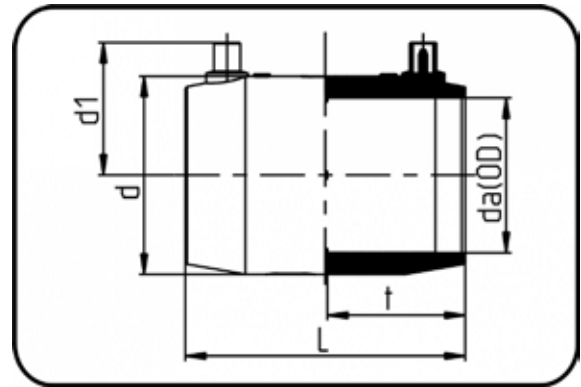

Code: 173

Dimension Dimension	Code Code	Detail Detail	da(OD) mm	L mm	d mm	d1 mm	t mm	Gewicht Weight
63	70.173.0063.11	63 SDR 17-7,4	63	124,5	83	59	62	0,26
75	70.173.0075.11	75 SDR 17-7,4	75	139,5	97	65,5	68,5	0,37
90	70.173.0090.11	90 SDR 17-7,4	90	138,5	112	72	68	0,44
110	70.173.0110.11	110 SDR 17-7,4	110	149	136	83	73	0,69
125	70.173.0125.11	125 SDR 17-7,4	125	169,5	155	91	83,5	0,99
140	70.173.0140.11	140 SDR 17-7,4	140	180	180	99	89,5	1,37
160	70.173.0160.11	160 SDR 17-7,4	160	180	197	109	88	1,76
180	70.173.0180.11	180 SDR 26-7,4	180	199,5	221	119	97,5	2,46
200	70.173.0200.11	200 SDR 26-7,4	200	215,5	245	127	105	3,14
225	70.173.0225.11	225 SDR 26-7,4	225	229	275	142	112	4,22
250	70.173.0250.11	250 SDR 26-7,4	250	238	310	155	116,5	4,81
280	70.173.0280.11	280 SDR 26-7,4	280	249	346	180	121,5	7,70
315	70.173.0315.11	315 SDR 26-7,4	315	260	390	187	127,5	7,89

E-Muffe

MOP Wasser 16bar / Gas 10bar

formgespritzt

Heizwendel-Schweissung

PE 100-RC schwarz

E-Coupler

MOP water 16bar/gas 10bar

injection moulded

Electro-fusion

PE 100-RC black

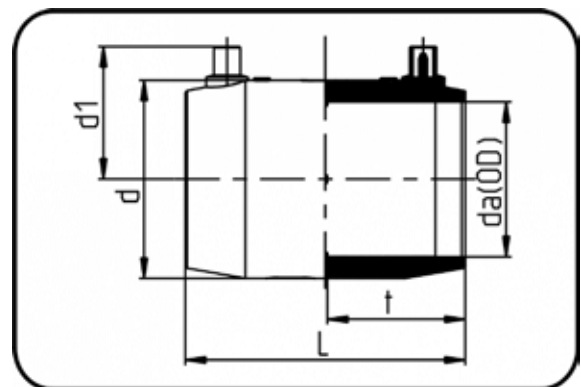

Code: 173

Dimension Dimension	Code Code	Detail Detail	da(OD) mm	L mm	d mm	d1 mm	t mm	Gewicht Weight
355	70.173.0355.11	355 SDR 26-11	355	280	445	225	136,5	14,75
400	70.173.0400.11	400 SDR 26-11	400	300	499	254	146,5	19,80
450	70.173.0450.11	450 SDR 17-11	450	338	552	260	166	20,60
500	70.173.0500.11	500 SDR 17-11	500	358	604	289	178,5	25,17

E-Muffe bifilar

E-Coupler bifilar

mechanisch gefertigt

machined

Heizwendel-Schweissung

Electro-fusion

PE 100-RC schwarz

PE 100-RC black

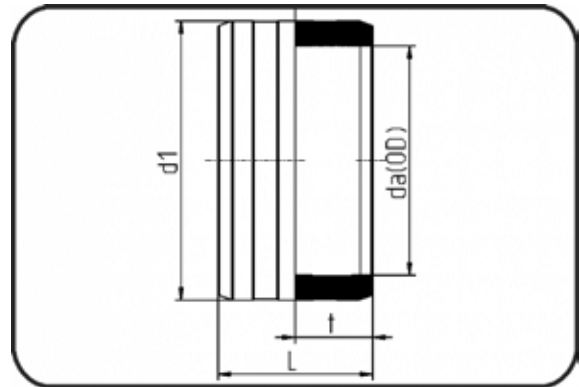

Code: 373

Dimension Dimension	Code Code	Detail Detail	da(OD) mm	L mm	d1 mm	t mm	Gewicht Weight
560	70.373.0560.11	560 SDR 17-11 MOP 16bar	560	380	685	190	44,00
630	70.373.0630.11	630 SDR 17-11 MOP 16bar	630	410	770	205	59,60

E-T-Stück

E-Tee

MOP Wasser 16bar / Gas 10bar

MOP water 16bar/gas 10bar

formgespritzt

injection moulded

Heizwendel-Schweissung

Electro-fusion

PE 100-RC schwarz

PE 100-RC black

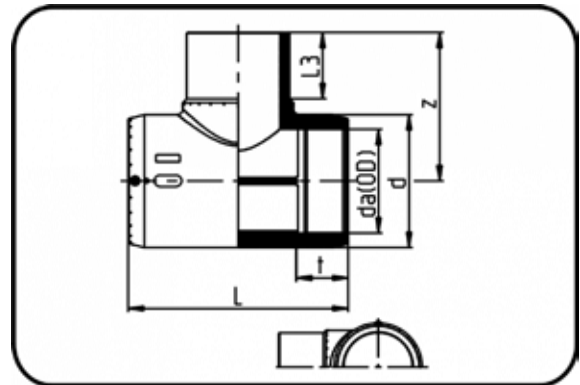

Code: 176

Dimension Dimension	Code Code	Detail Detail	da(OD) mm	z mm	L mm	L3 mm	d mm	t mm	Gewicht Weight
63	70.176.0063.11	63 SDR 17-11	63	116	185,5	64,5	88	62	0,56
75	70.176.0075.11	75 SDR 17-11	75	128	210,5	71,5	97	69	0,64
90	70.176.0090.11	90 SDR 17-11	90	168,5	293	91	124	76	1,75
110	70.176.0110.11	110 SDR 17-11	110	191	326,5	101	148,5	71,5	2,63
125	70.176.0125.11	125 SDR 17-11	125	211	347,5	111	170	86	3,70
160	70.176.0160.11	160 SDR 17-11	160	245	370,5	122	211,5	85	6,12
180	70.176.0180.11	180 SDR 17-11	180	275	419,5	130	232	98,5	8,85
225	70.176.0225.11	225 SDR 17-11	225	325	479,5	147	287	110	13,40

Product range 218 psi

E-Winkel 90°

MOP Wasser 16bar / Gas 10bar

formgespritzt

Heizwendel-Schweissung

PE 100-RC schwarz

E-Elbow 90°

MOP water 16bar/gas 10bar

injection moulded

Electro-fusion

PE 100-RC black

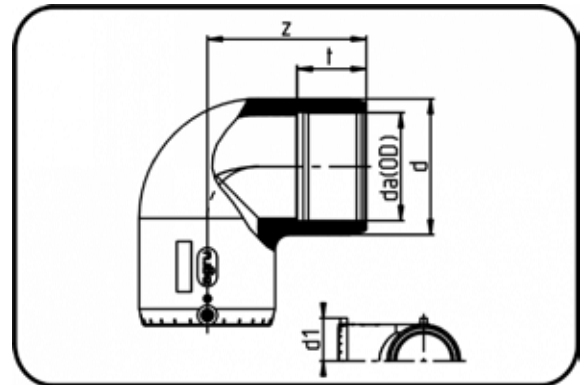

Code: 171

Dimension Dimension	Code Code	Detail Detail	da(OD) mm	z mm	d mm	d1 mm	t mm	Gewicht Weight
63	70.171.0063.11	63 SDR 17-11	63	99	83	60	62,7	0,39
75	70.171.0075.11	75 SDR 17-11	75	114	97	66	70	0,61
90	70.171.0090.11	90 SDR 17-11	90	147	114	73	70,5	1,06
110	70.171.0110.11	110 SDR 17-11	110	164	140	82,5	70,5	1,80
125	70.171.0125.11	125 SDR 17-11	125	164	161	91	84	2,46
160	70.171.0160.11	160 SDR 17-11	160	222	200	109	87	4,70
180	70.171.0180.11	180 SDR 26-11	180	230	224	118	98,5	6,25
200	70.171.0200.11	200 SDR 26-11	200	250	248	129,5	106,5	8,00
225	70.171.0225.11	225 SDR 17-11	225	274	279	144	112,5	10,80

E-Winkel 45°

MOP Wasser 16bar / Gas 10bar

formgespritzt

Heizwendel-Schweissung

PE 100-RC schwarz

E-Elbow 45°

MOP water 16bar/gas 10bar

injection moulded

Electro-fusion

PE 100-RC black

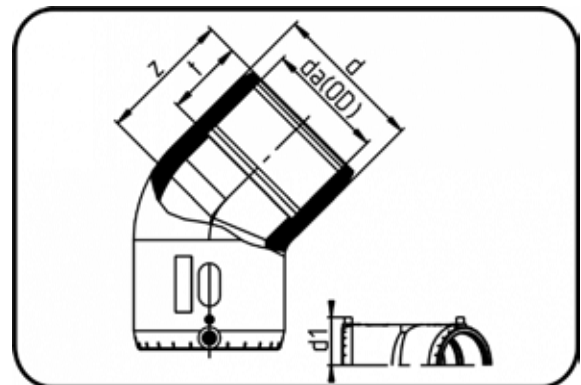

Code: 170

Dimension Dimension	Code Code	Detail Detail	da(OD) mm	z mm	d mm	d1 mm	t mm	Gewicht Weight
63	70.170.0063.11	63 SDR 17-11	63	82	82,5	58,5	61,5	0,33
75	70.170.0075.11	75 SDR 17-11	75	94	97	66	68,5	0,50
90	70.170.0090.11	90 SDR 17-11	90	113	115	74	71	0,85
110	70.170.0110.11	110 SDR 17-11	110	124	140	82,5	72	1,44
125	70.170.0125.11	125 SDR 17-11	125	124	161	92	85	1,91
160	70.170.0160.11	160 SDR 17-11	160	161,5	200	112	89	3,40
180	70.170.0180.11	180 SDR 26-11	180	172	224	119	98	4,89
200	70.170.0200.11	200 SDR 26-11	200	178	248,5	130,5	106,5	6,00
225	70.170.0225.11	225 SDR 17-11	225	190	279	145,5	113,5	7,99

E-Reduktion konzentrisch

MOP Wasser 16bar / Gas 10bar

formgespritzt

Heizwendel-Schweissung

PE 100-RC schwarz

E-Reducer concentric

MOP water 16bar/gas 10bar

injection moulded

Electro-fusion

PE 100-RC black

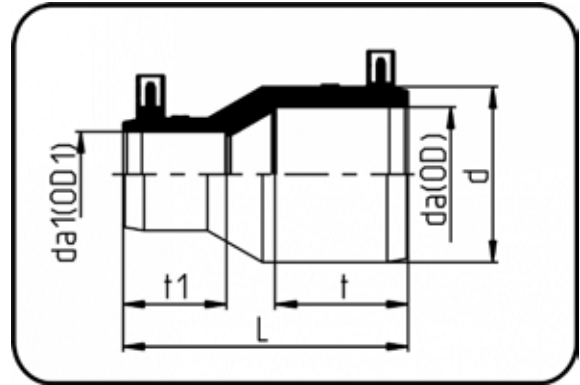

Code: 177

Dimension Dimension	Code Code	Detail Detail	da(OD) mm	da1(OD1) mm	L mm	d mm	t mm	t1 mm	Gewicht Weight
75/63	70.177.7563.11	75/63 SDR 17-11	75	63	155,5	97	69	61,5	0,38
90/63	70.177.9063.11	90/63 SDR 17-11	90	63	171,5	117	71,5	62,5	0,56
110/63	70.177.1163.11	110/63 SDR 17-11	110	63	200,5	140,5	72	62,5	0,86
110/90	70.177.1190.11	110/90 SDR 17-11	110	90	180,5	140,5	72	71	0,94
125/90	70.177.1290.11	125/90 SDR 17-11	125	90	183,5	156	83	68,7	0,99
125/110	70.177.1211.11	125/110 SDR 17-11	125	110	173,5	156	82	69,5	1,05
160/90	70.177.1690.11	160/90 SDR 17-11	160	90	240,5	200	89,5	71	1,89
160/110	70.177.1611.11	160/110 SDR 17-11	160	110	224,5	200	89,5	71	1,98
225/160	70.177.2216.11	225/160 SDR 17-11	225	160	282	280	113	88	5,12

E-Endkappe

MOP Wasser 16bar / Gas 10bar

formgespritzt

Heizwendel-Schweissung

PE 100-RC schwarz

E-End Cap

MOP water 16bar/gas 10bar

injection moulded

Electro-fusion

PE 100-RC black

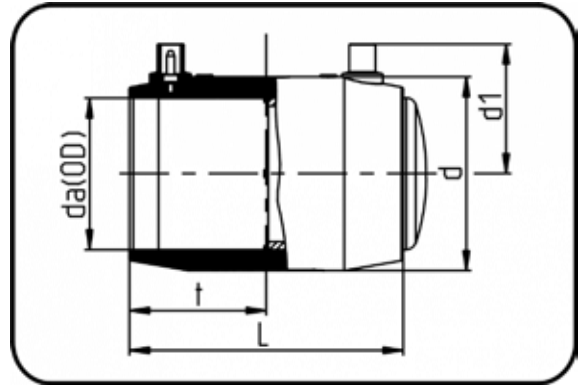

Code: 174

Dimension Dimension	Code Code	Detail Detail	da(OD) mm	L mm	d mm	d1 mm	t mm	Gewicht Weight
63	70.174.0063.11	63 SDR 17-11	63	124,5	83	59	62	0,35
75	70.174.0075.11	75 SDR 17-11	75	139,5	97	65,5	68,5	0,50
90	70.174.0090.11	90 SDR 17-11	90	138,5	112	72	68	0,69
110	70.174.0110.11	110 SDR 17-11	110	149	136	83	73	1,23
125	70.174.0125.11	125 SDR 17-11	125	169,5	155	91	83,5	1,62
140	70.174.0140.11	140 SDR 17-11	140	180	180	99	88,5	2,40
160	70.174.0160.11	160 SDR 17-11	160	180	197	107,5	88	2,92
180	70.174.0180.11	180 SDR 26-11	180	199,5	221	119	97,5	3,92
200	70.174.0200.11	200 SDR 17-11	200	215,5	245	127	105	5,21
225	70.174.0225.11	225 SDR 17-11	225	229	275	142	112	7,20
250	70.174.0250.11	250 SDR 26-11	250	238	310	155	116,5	8,84
280	70.174.0280.11	280 SDR 26-11	280	249	346	180	121,5	12,66
315	70.174.0315.11	315 SDR 26-11	315	260	386	187	127,5	14,70

Stutzschelle

MOP Wasser 16bar
Unterteil schraubbar
formgespritzt

Heizwendel-Schweissung

PE 100-RC schwarz

Spigot saddle

MOP water 16bar
bottom part screwable
injection moulded

Electro-fusion

PE 100-RC black

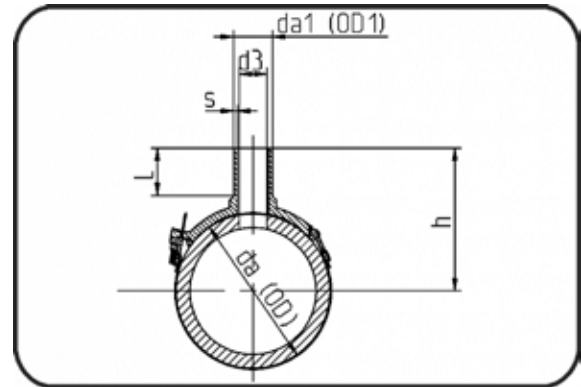

Code: 288

Dimension Dimension	Code Code	Detail Detail	da(OD) mm	da1(OD1) mm	d3 mm	s mm	L mm	Gewicht Weight
90/63	70.288.9063.11	90/63 SDR 17 - 11	90	63	45	5,8	77	0,26
110/63	70.288.1163.11	110/63 SDR 17 - 11	110	63	45	5,8	77	0,31
125/63	70.288.1263.11	125/63 SDR 17 - 11	125	63	45	5,8	77	0,32
140/63	70.288.1463.11	140/63 SDR 17 - 11	140	63	45	5,8	77	0,32
160/63	70.288.1663.11	160/63 SDR 17 - 11	160	63	45	5,8	77	0,51
160/90	70.288.1690.11	160/90 SDR 17 - 11	160	90	65	8,2	92	0,88
160/110	70.288.1611.11	160/110 SDR 17 - 11	160	110	84	10	98	0,95
180/63	70.288.1863.11	180/63 SDR 17 - 11	180	63	45	5,8	77	0,59
180/90	70.288.1890.11	180/90 SDR 17 - 11	180	90	65	8,2	92	1,01
180/110	70.288.1811.11	180/110 SDR 17 - 11	180	110	84	10	98	1,10
225/63	70.288.2263.11	225/63 SDR 17 - 11	225	63	45	5,8	77	0,56
225/90	70.288.2290.11	225/90 SDR 17 - 11	225	90	65	8,2	92	0,94
225/110	70.288.2211.11	225/110 SDR 17 - 11	225	110	84	10	97	1,02
250/63	70.288.2563.11	250/63 SDR 17 - 11	250	63	45	5,8	77	0,55
250/75	70.288.2575.11	250/75 SDR 17 - 11	250	75	55	6,8	86	0,73
250/90	70.288.2590.11	250/90 SDR 17 - 11	250	90	65	8,2	92	0,99
250/110	70.288.2511.11	250/110 SDR 17 - 11	250	110	84	10	98	1,07
280/63	70.288.2863.11	280/63 SDR 17 - 11	280	63	45	5,8	77	0,55
280/90	70.288.2890.11	280/90 SDR 17 - 11	280	90	65	8,2	92	1,04
280/110	70.288.2811.11	280/110 SDR 17 - 11	280	110	84	10	98	1,07
315/63	70.288.3163.11	315/63 SDR 17 - 11	315	63	45	5,8	77	0,62
315/90	70.288.3190.11	315/90 SDR 17 - 11	315	90	65	8,2	92	1,06
315/110	70.288.3111.11	315/110 SDR 17 - 11	315	110	84	10	98	1,19
355/63	70.288.3563.11	355/63 SDR 17 - 11	315	63	45	5,8	77	0,62
355/90	70.288.3590.11	355/90 SDR 17 - 11	315	90	65	8,2	92	1,06
355/110	70.288.3511.11	355/110 SDR 17 - 11	315	110	84	10	98	1,19

**Stutzenschelle System
Topload**

mechanisch gefertigt

Heizwendel-Schweissung

PE 100-RC schwarz

**Spigot saddle System
Topload**

machined

Electro-fusion

PE 100-RC black

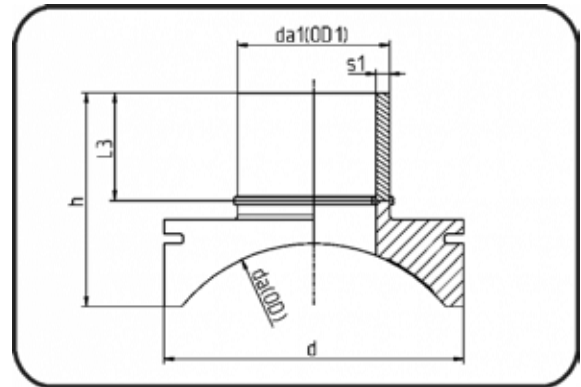

Code: 289

Dimension Dimension	Code Code	Detail Detail	da(OD) mm	da1(OD1) mm	h mm	d mm	s1 mm	L3 mm	Gewicht Weight
355/90	70.289.3590.11	355/90 SDR11 MOP 16 bar	355	90	176	200	8,2	94	1,08
355/110	70.289.3511.11	355/110 SDR11 MOP 16 bar	355	110	194	250	10	97	2,23
355/125	70.289.3512.11	355/125 SDR11 MOP 16 bar	355	125	209	280	11,4	102	2,98
400/90	70.289.4090.11	400/90 SDR11 MOP 16 bar	400	90	173	200	8,2	94	1,26
400/110	70.289.4011.11	400/110 SDR11 MOP 16 bar	400	110	189	250	10	97	2,18
400/125	70.289.4012.11	400/125 SDR11 MOP 16 bar	400	125	204	280	11,4	102	2,90
450/90	70.289.4590.11	450/90 SDR11 MOP 16 bar	450	90	171	200	8,2	94	1,05
450/110	70.289.4511.11	450/110 SDR11 MOP 16 bar	450	110	186	250	10	97	1,88
450/125	70.289.4512.11	450/125 SDR11 MOP 16 bar	450	125	199	280	11,4	102	3,30
500/90	70.289.5090.11	500/90 SDR11 MOP 16 bar	500	90	168	200	8,2	94	1,22
500/110	70.289.5011.11	500/110 SDR11 MOP 16 bar	500	110	182	250	10	97	1,86
500/125	70.289.5012.11	500/125 SDR11 MOP 16 bar	500	125	195	280	11,4	102	2,74
560/90	70.289.5690.11	560/90 SDR11 MOP 16 bar	560	90	166	200	8,2	94	1,07
560/110	70.289.5611.11	560/110 SDR11 MOP 16 bar	560	110	179	250	10	97	1,81
560/125	70.289.5612.11	560/125 SDR11 MOP 16 bar	560	125	191	280	11,4	102	2,68
630/90	70.289.6390.11	630/90 SDR11 MOP 16 bar	630	90	166	200	8,2	94	1,18
630/110	70.289.6311.11	630/110 SDR11 MOP 16 bar	630	110	176	250	10	97	1,98
630/125	70.289.6312.11	630/125 SDR11 MOP 16 bar	630	125	188	280	11,4	102	2,60

MOP auf Anfrage. Spannvorrichtung siehe bitte unter Schweisstechnik.

MOP on request. Installation Set please see Welding Technology.

Losflansch DIN

Stahleinlage/für V-Bund

formgespritzt+gebohrt PN10/16

Flanschverbindung

PP-GFK schwarz

Backing Ring DIN

steel insert/for stub flange

inj. moulded+drilled PN10/16

Flange connection

PP-FRP black

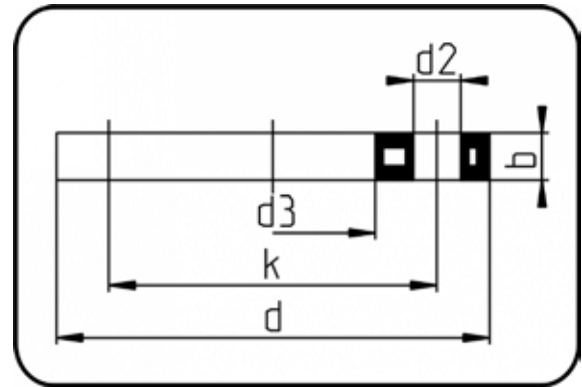

Code: 14.014

Dimension Dimension	Code Code	Detail Detail	da(OD) mm	d mm	d2 mm	d3 mm	b mm	k mm	Gewicht Weight
63	14.014.0063.11	63 - MOP 16 bar	63	165	18	78	18	125	0,79
75	14.014.0075.11	75 - MOP 16 bar	75	186	18	92	18	145	1,11
90	14.014.0090.11	90 - MOP 16 bar	90	202	18	108	20	160	1,16
110	14.014.0110.11	110 - MOP 16 bar	110	220	18	128	20	180	1,33
125	14.014.0125.11	125 - MOP 16 bar	125	220	18	135	20	180	1,22
140	14.014.0140.11	140 - MOP 16 bar	140	250	18	158	24	210	1,94
160	14.014.0160.11	160 - MOP 16 bar	160	285	22	178	23	240	2,60
180	14.014.0180.11	180 - MOP 16 bar	180	285	22	190	23	240	2,24

Losflansch DIN

Stahleinlage/für V-Bund

formgespritzt+gebohrt PN10

Flanschverbindung

PP-GFK schwarz

Backing Ring DIN

steel insert/for stub flange

injection moulded+drilled PN10

Flange connection

PP-FRP black

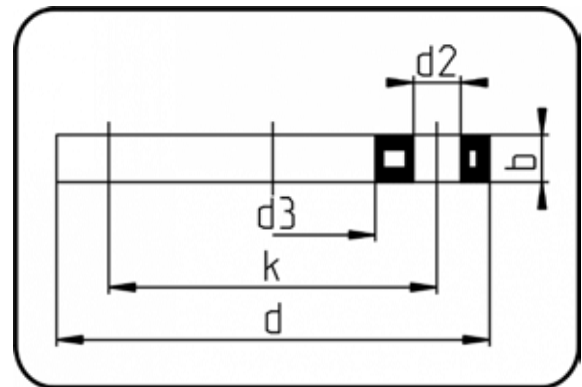

Code: 14.014

Dimension Dimension	Code Code	Detail Detail	da(OD) mm	d mm	d2 mm	d3 mm	b mm	k mm	Gewicht Weight
200	14.014.0200.11	200 - MOP 16 bar	200	340	22	235	25	295	2,66
225	14.014.0225.11	225 - MOP 16 bar	225	340	22	238	25	295	2,80
250	14.014.0250.11	250 - MOP 16 bar	250	409	22	288	30	350	6,40
280	14.014.0280.11	280 - MOP 16 bar	280	409	22	294	30	350	6,40
315	14.014.0315.11	315 - MOP 16 bar	315	463	23	338	34	400	9,60
355	14.014.0355.11	355 - MOP 16 bar	355	515	22,5	376	42	460	14,60
400	14.014.0400.11	400 - MOP 16 bar	400	574	26	430	46	515	17,74
450	14.014.0450.11	450/DN500 - MOP 16 bar	450	678	26	517	45	620	24,96
500	14.014.0500.11	500 - MOP 16 bar	500	678	26	533	45	620	24,38
560	14.014.0560.11	560 - MOP 10 bar	560	789	30	618	50	725	33,40
630	14.014.0630.11	630 - MOP 10 bar	630	789	30	645	50	725	32,62

Losflansch DIN

Stahleinlage/für V-Bund

formgespritzt+gebohrt PN16

Flanschverbindung

PP-GFK schwarz

Backing Ring DIN

steel insert/for stub flange

injection moulded+drilled PN16

Flange connection

PP-FRP black

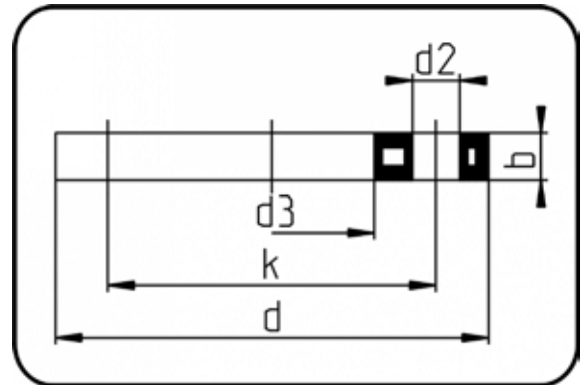

Code: 14.014.1

Dimension Dimension	Code Code	Detail Detail	da(OD) mm	d mm	d2 mm	d3 mm	b mm	k mm	Gewicht Weight
200	14.014.1200.11	200 - MOP 16 bar	200	340	22	235	24	295	3,00
225	14.014.1225.11	225 - MOP 16 bar	225	340	22	238	24	295	2,85
250	14.014.1250.11	250 - MOP 16 bar	250	418	26	288	30	355	7,00
280	14.014.1280.11	280 - MOP 16 bar	280	418	26	294	30	355	6,80
315	14.014.1315.11	315 - MOP 16 bar	315	478	26	338	30	410	8,40
355	14.014.1355.11	355 - MOP 16 bar	355	530	26	376	42	470	16,70
400	14.014.1400.11	400 - MOP 16 bar	400	599	30	430	41	525	17,00

Blindflansch DIN

Stahleinlage

formgespritzt+gebohrt PN10/16

Flanschverbindung

PP-GFK schwarz

Blind Flange DIN

steel insert

inj. moulded+drilled PN10/16

Flange connection

PP-FRP black

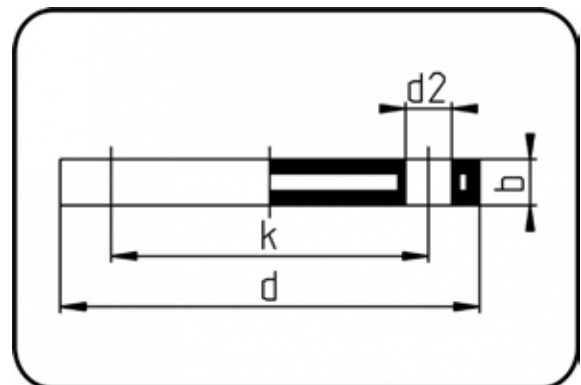

Code: 14.045

Dimension Dimension	Code Code	Detail Detail	da(OD) mm	d mm	d2 mm	b mm	k mm	p bar	Gewicht Weight
63	14.045.0063.11	63 - MOP 16 bar	63	165	18	17	125	16	1,15
75	14.045.0075.11	75 - MOP 16 bar	75	185,5	18	19	145	16	1,64
90	14.045.0090.11	90 - MOP 16 bar	90	202	18	20	160	16	1,96
110/125	14.045.0110.11	110/125 - MOP 16 bar	110	220	18	20	180	16	2,36
140	14.045.0140.11	140 - MOP 16 bar	140	250	18	24,5	210	16	3,92
160/180	14.045.0160.11	160/180 - MOP 16 bar	160	285	22	23	240	16	5,06

Blindflansch DIN

Stahleinlage

formgespritzt+gebohrt PN10

Flanschverbindung

PP-GFK schwarz

Blind Flange DIN

steel insert

injection moulded+drilled PN10

Flange connection

PP-FRP black

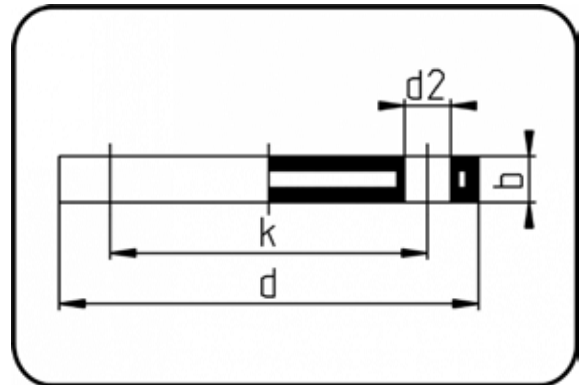

Code: 14.045

Dimension Dimension	Code Code	Detail Detail	da(OD) mm	d mm	d2 mm	b mm	k mm	p bar	Gewicht Weight
200/225	14.045.0200.11	200/225 - MOP 16 bar	200	340	22	25	295	16	6,50
250/280	14.045.0250.11	250/280 - MOP 10 bar	250	409	22	30	350	10	15,40
315	14.045.0315.11	315 - MOP 10 bar	315	463	22	34	400	10	26,00
355	14.045.0355.11	355 - MOP 10 bar	355	515	22	42	460	10	39,66
400	14.045.0400.11	400 - MOP 10 bar	400	574	27	46	515	10	50,44

Blindflansch DIN

Stahl verzinkt

gebohrt PN10

Flanschverbindung

Stahl verzinkt

Blind Flange DIN

steel galvanized

drilled PN10

Flange connection

steel galvanized

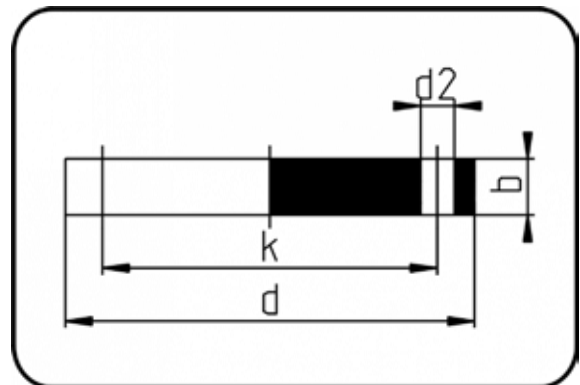

Code: 90.045

Dimension Dimension	Code Code	Detail Detail	da(OD) mm	d mm	d2 mm	b mm	k mm	Gewicht Weight
450/500	90.045.0450.17	450/500 - MOP 16 bar	450	670	26	28	620	124,00

** Auf Anfrage.

** On request.

Losflansch ANSI

Stahleinlage

formgespritzt

Flanschverbindung

PP-GFK grau

Backing Ring ANSI

steel insert

injection moulded

Flange connection

PP-FRP grey

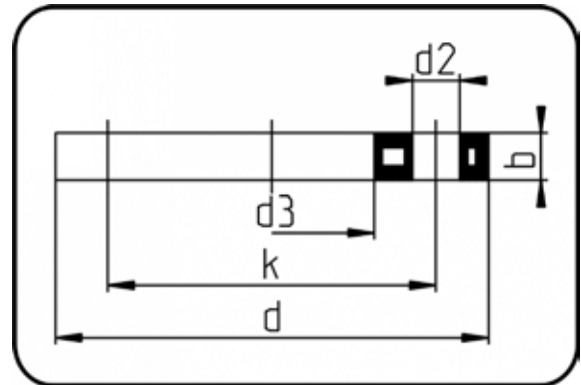

Code: 11.013

Dimension Dimension	Code Code	Detail Detail	da(OD) mm	d mm	d2 mm	d3 mm	b mm	k mm	Gewicht Weight
63	11.013.0063.11	63 - 2" - MOP 16 bar	63	162	20	78	18	120,65	0,81
75	11.013.0075.11	75 - 2 1/2" - MOP 16 bar	75	184	20	92	18	139,7	1,07
90	11.013.0090.11	90 - 3" - MOP 16 bar	90	194	20	111	18	152,4	1,03
110/125	11.013.0110.11	110/125 - 4" - MOP 16 bar	110	229	20	133	18	190,5	1,55
160	11.013.0160.11	160 - 6" - MOP 16 bar	160	283	22	178	24	241,3	2,32
200/225	11.013.0200.11	200/225 - 8" - MOP 16 bar	200	345	22	236	24	298,45	3,43
250/280	11.013.0250.11	250/280 - 10" - MOP 16 bar	250	412	25	288	26	361,95	6,10
315	11.013.0315.11	315 - 12" - MOP 16 bar	315	487	25	338	32	431,8	13,00

Losflansch ANSI

Stahleinlage

formgespritzt

Flanschverbindung

PP-GFK schwarz

Backing Ring ANSI

steel insert

injection moulded

Flange connection

PP-FRP black

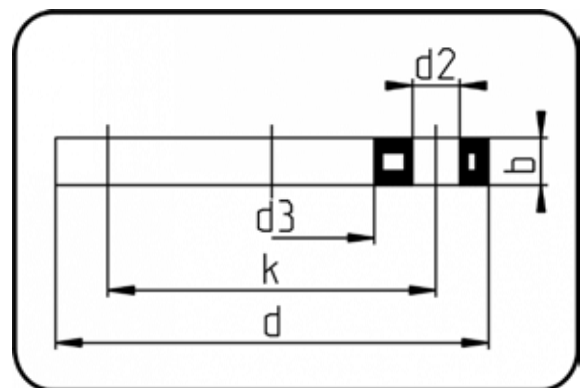

Code: 013

Dimension Dimension	Code Code	Detail Detail	da(OD) mm	d mm	d2 mm	d3 mm	b mm	k mm	Gewicht Weight
63	14.013.0063.11	63 - 2" - MOP 16 bar	63	162	20	78	18	120,65	0,81
75	14.013.0075.11	75 - 2 1/2" - MOP 16 bar	75	184	20	92	18	139,7	1,07
90	14.013.0090.11	90 - 3" - MOP 16 bar	90	194	20	111	18	152,4	1,08
110/125	14.013.0110.11	110/125 - 4" - MOP 16 bar	110	229	20	133	18	190,5	1,56
160	14.013.0160.11	160 - 6" - MOP 16 bar	160	283	22	178	24	241,3	2,35
200/225	14.013.0200.11	200/225 - 8" - MOP 16 bar	200	345	22	236	24	298,45	3,39
250/280	14.013.0250.11	250/280 - 10" - MOP 16 bar	250	412	25	288	26	361,95	6,20
315	14.013.0315.11	315 - 12" - MOP 16 bar	315	487	25	338	32	431,8	12,60

Losflansch ANSI

Stahl verzinkt

ASME B16.5 Class 150

Flanschverbindung

Stahl verzinkt

Backing Ring ANSI

steel galvanized

ASME B16.5 Class 150

Flange connection

steel galvanized

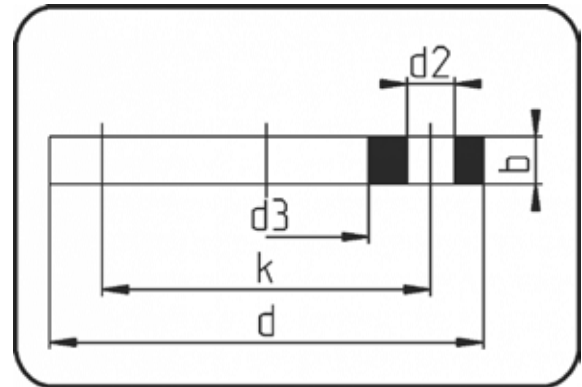

Code: 90.013

Dimension Dimension	Code Code	Detail Detail	da(OD) mm	d mm	d2 mm	d3 mm	b mm	k mm	Gewicht Weight
355	90.013.0355.17	355 - 14" MOP 20 bar	355	535	29	376	33,4	476,25	28,00
400	90.013.0400.17	400 - 16" MOP 20 bar	400	595	29	430	35	539,75	34,00
450	90.013.0450.17	450 - 18" MOP 20 bar	450	635	32	492	38,1	577,85	42,03
500	90.013.0500.17	500 - 20" MOP 20 bar	500	700	32	533	41,3	635	47,00
560	90.013.0560.17	560 - 22" MOP 20 bar	560	750	35	618	30,2	692,15	45,40
630	90.013.0630.17	630 - 24" MOP 20 bar	560	815	35	645	46,1	749,3	58,03

** Auf Anfrage.

** On request.

Blindflansch ANSI

Stahleinlage

formgespritzt

Flanschverbindung

PP-GFK grau

Blind Flange ANSI

steel insert

injection moulded

Flange connection

PP-FRP grey

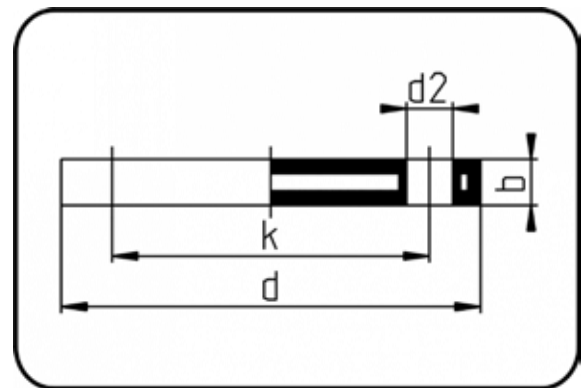

Code: 11.043

Dimension Dimension	Code Code	Detail Detail	da(OD) mm	d mm	d2 mm	b mm	k mm	Gewicht Weight
63	11.043.0063.11	63 - 2" - MOP 16 bar	63	162	20	18,5	120,65	1,22
75	11.043.0075.11	75 - 2 1/2" - MOP 16 bar	75	184	20	18	139,7	1,54
90	11.043.0090.11	90 - 3" - MOP 16 bar	90	194	20	18	152,4	1,84
110/125	11.043.0110.11	110/125 - 4" - MOP 16 bar	110	229	20	18	190,5	2,88
160	11.043.0160.11	160 - 6" - MOP 16 bar	160	283	22	24	241,3	5,10
200/225	11.043.0200.11	200/225 - 8" - MOP 16 bar	200	345	22	24	298,45	7,92
250/280	11.043.0250.11	250/280 - 10" - MOP 16 bar	250	412	25	27	361,95	15,15
315	11.043.0315.11	315 - 12" - MOP 16 bar	315	487	25	33	431,8	28,80

Blindflansch ANSI

Stahl verzinkt

ASME B16.5 Class 150

Flanschverbindung

Stahl verzinkt

Blind Flange ANSI

steel galvanized

ASME B16.5 Class 150

Flange connection

steel galvanized

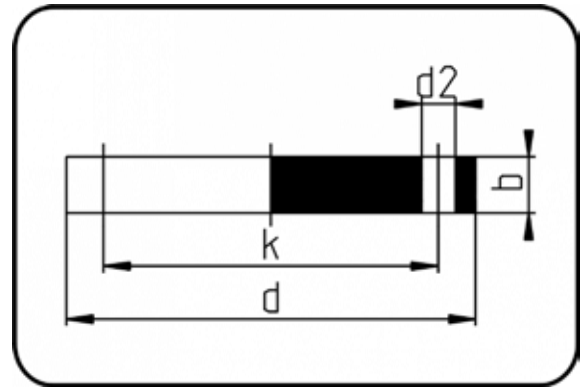

Code: 90.043

Dimension Dimension	Code Code	Detail Detail	da(OD) mm	d mm	d2 mm	b mm	k mm	Gewicht Weight
355	90.043.0355.17	355 - 14" MOP 20 bar	355	535	29	33,4	476,25	57,00
400	90.043.0400.17	400 - 16" MOP 20 bar	400	595	29	35	539,75	68,00
450	90.043.0450.17	450 - 18" MOP 20 bar	450	635	32	38,1	577,85	102,00
500	90.043.0500.17	500 - 20" MOP 20 bar	500	700	32	41,3	635	120,00

** Auf Anfrage.

** On request.

PE 100 / PE100-RC ROHRSYSTEM FM 250 PSI
PE 100 / PE100-RC PIPING SYSTEM FM 250 PSI



ROHRE
PIPES

Seite
page

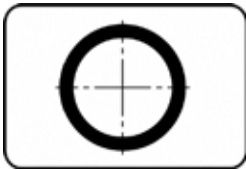

Code: 722

Rohr schwarz 12m
FM zugelassen
extrudiert
PE 100-RC schwarz

Pipe black 12m
FM approved
extruded
PE 100-RC black

215

VERLÄNGERTE FITTINGS
ELONGATED FITTINGS

Seite
page

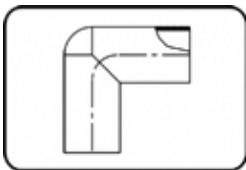

Code: 061

Winkel 90°
lange Schenkel
formgespritzt+ausgedreht
PE 100-RC schwarz

Elbow 90°
long spigot
injection moulded+chamfered
PE 100-RC black

216

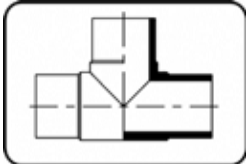

Code: 066

T-Stück
lange Schenkel
formgespritzt+ausgedreht
PE 100-RC schwarz

Tee
long spigot
injection moulded+chamfered
PE 100-RC black

216

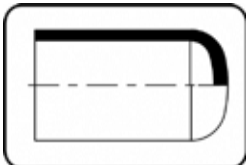

Code: 064

Endkappe
lange Schenkel
formgespritzt+ausgedreht
PE 100-RC schwarz

End Cap
long spigot
injection moulded+chamfered
PE 100-RC black

217

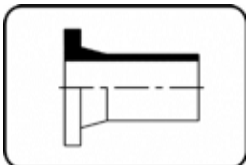

Code: 062

Vorschweissbund DIN
lange Schenkel
formgespritzt+ausgedreht
PE 100-RC schwarz

Stub Flange DIN
long spigot
injection moulded+chamfered
PE 100-RC black

217

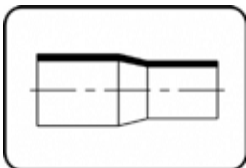

Code: 067

Reduktion konzentrisch
lange Schenkel
formgespritzt+ausgedreht
PE 100-RC schwarz

Reducer concentric
long spigot
injection moulded+chamfered
PE 100-RC black

218

ROHRBÖGEN
SWEEP BENDS

Seite
page

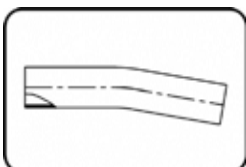

Code: 394

Rohrbogen 11°
Radius 1,5 x da
aus Rohr geformt
PE 100-RC schwarz

Sweep Bend 11°
radius 1.5 x OD
formed out of pipe
PE 100-RC black

219

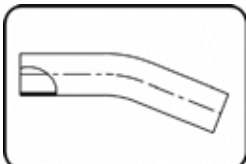

Code: 395

Rohrbogen 22°
Radius 1,5 x da
aus Rohr geformt
PE 100-RC schwarz

Sweep bend 22°
radius 1.5 x OD
formed out of pipe
PE 100-RC black

220

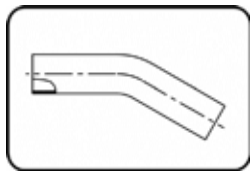

Code: 396

Rohrbogen 30°
Radius 1,5 x da
aus Rohr geformt
PE 100-RC schwarz

Sweep Bend 30°
radius 1.5 x OD
formed out of pipe
PE 100-RC black

221

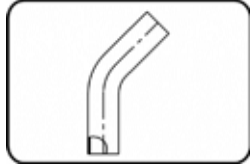

Code: 397

Rohrbogen 45°
Radius 1,5 x da
aus Rohr geformt
PE 100-RC schwarz

Sweep Bend 45°
radius 1.5 x OD
formed out of pipe
PE 100-RC black

222

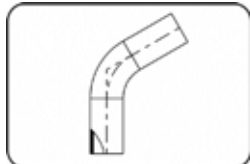

Code: 398

Rohrbogen 60°
Radius 1,5 x da
aus Rohr geformt
PE 100-RC schwarz

Sweep Bend 60°
radius 1.5 x OD
formed out of pipe
PE 100-RC black

223

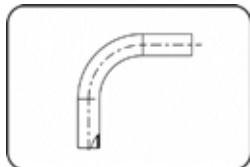

Code: 399

Rohrbogen 90°
Radius 1,5 x da
aus Rohr geformt
PE 100-RC schwarz

Sweep Bend 90°
radius 1.5 x OD
formed out of pipe
PE 100-RC black

224

KURZSCHENKELIGE FITTINGS FITTINGS WITH SHORT SPIGOT

Seite
page

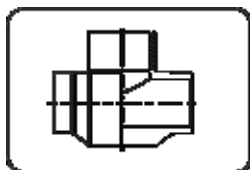

Code: 307.1

T-Stück
kurze Schenkel
mechanisch gefertigt
PE 100-RC schwarz

Tee
short spigot
machined
PE 100-RC black

225

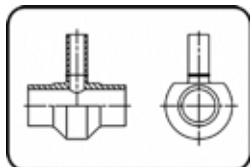

Code: 307

T-Stück reduziert
kurze Schenkel
mechanisch gefertigt
PE 100-RC schwarz

Tee reduced
short spigot
machined
PE 100-RC black

226



Code: 317

Reduktion konzentrisch
kurze Schenkel
mechanisch gefertigt
PE 100-RC schwarz

Reducer concentric
short spigot
machined
PE 100-RC black

230

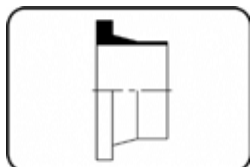

Code: 312

Vorschweissbund DIN
kurze Schenkel
mechanisch gefertigt
PE 100-RC schwarz

Stub Flange DIN
short spigot
machined
PE 100-RC black

232

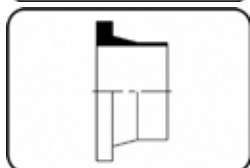

Code: 314

Vorschweissbund ANSI
kurze Schenkel
mechanisch gefertigt
PE 100-RC schwarz

Stub Flange ANSI
short spigot
machined
PE 100-RC black

233

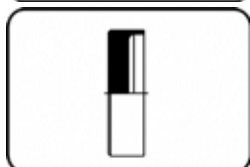

Code: 302

Endkappe
kurze Schenkel
mechanisch gefertigt
PE 100-RC schwarz

End Cap
short spigot
machined
PE 100-RC black

234

SEGMENTIERTE FITTINGS
SEGMENTED FITTINGS

Seite
page

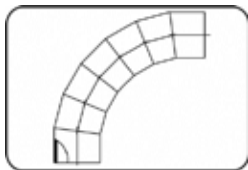

Code: 328
Bogen 90°
7 Segmente
segmentiert
PE 100-RC schwarz

Bend 90°
7 segments
segmented
PE 100-RC black

235

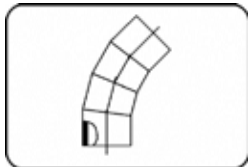

Code: 327
Bogen 45°
4 Segmente
segmentiert
PE 100-RC schwarz

Bend 45°
4 segments
segmented
PE 100-RC black

235

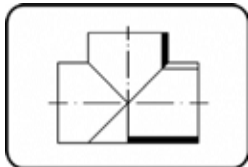

Code: 326
T-Stück segmentiert
SDR7,4 ausgedreht auf SDR9
PE 100-RC schwarz

Tee segmented
SDR7,4 machined to SDR9

PE 100-RC black

236

E-SCHWEISSBARE FITTINGS
ELECTRO FUSION FITTINGS

Seite
page

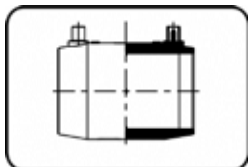

Code: 173
E-Muffe
MOP Wasser 25bar / Gas 10bar
formgespritzt
PE 100-RC schwarz

E-Coupler
MOP water 25bar/gas 10bar
injection moulded
PE 100-RC black

237

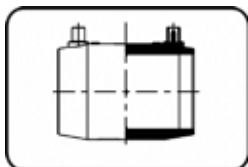

Code: 173
E-Muffe
MOP Wasser 16bar / Gas 10bar
formgespritzt
PE 100-RC schwarz

E-Coupler
MOP water 16bar/gas 10bar
injection moulded
PE 100-RC black

237

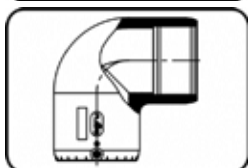

Code: 171
E-Winkel 90°
MOP Wasser 16bar / Gas 10bar
formgespritzt
PE 100-RC schwarz

E-Elbow 90°
MOP water 16bar/gas 10bar
injection moulded
PE 100-RC black

238

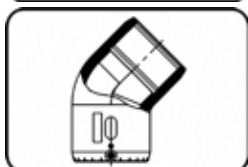

Code: 170
E-Winkel 45°
MOP Wasser 16bar / Gas 10bar
formgespritzt
PE 100-RC schwarz

E-Elbow 45°
MOP water 16bar/gas 10bar
injection moulded
PE 100-RC black

238

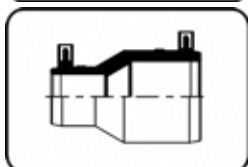

Code: 177
E-Reduktion konzentrisch
MOP Wasser 16bar / Gas 10bar
formgespritzt
PE 100-RC schwarz

E-Reducer concentric
MOP water 16bar/gas 10bar
injection moulded
PE 100-RC black

239

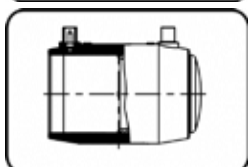

Code: 174
E-Endkappe
MOP Wasser 16bar / Gas 10bar
formgespritzt
PE 100-RC schwarz

E-End Cap
MOP water 16bar/gas 10bar
injection moulded
PE 100-RC black

240

SCHELLEN
SADDLES

Seite
page

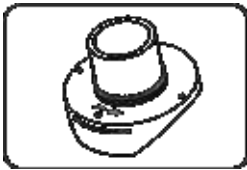

Code: 289

Stutzenschelle System Topload

Spigot saddle System Topload

mechanisch gefertigt
PE 100-RC schwarz

machined
PE 100-RC black

241

FLANSCH, ZUBEHÖR
BACKING RINGS, ACCESSORIES

Seite
page

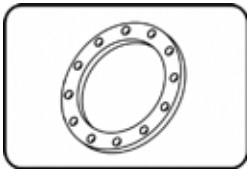

Code: 14.014

Losflansch DIN

Backing Ring DIN

Stahleinlage/für V-Bund
formgespritzt+gebohrt PN10/16
PP-GFK schwarz

steel insert/for stub flange
inj. moulded+drilled PN10/16
PP-FRP black

242

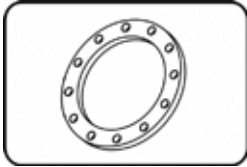

Code: 14.014

Losflansch DIN

Backing Ring DIN

Stahleinlage/für V-Bund
formgespritzt+gebohrt PN10
PP-GFK schwarz

steel insert/for stub flange
injection moulded+drilled PN10
PP-FRP black

242

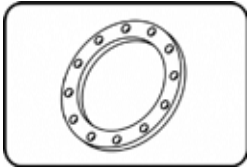

Code: 14.014.1

Losflansch DIN

Backing Ring DIN

Stahleinlage/für V-Bund
formgespritzt+gebohrt PN16
PP-GFK schwarz

steel insert/for stub flange
injection moulded+drilled PN16
PP-FRP black

243

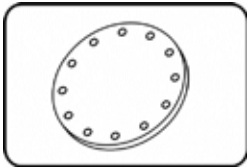

Code: 14.045

Blindflansch DIN

Blind Flange DIN

Stahleinlage
formgespritzt+gebohrt PN10/16
PP-GFK schwarz

steel insert
inj. moulded+drilled PN10/16
PP-FRP black

243

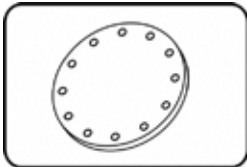

Code: 14.045

Blindflansch DIN

Blind Flange DIN

Stahleinlage
formgespritzt+gebohrt PN10
PP-GFK schwarz

steel insert
injection moulded+drilled PN10
PP-FRP black

244

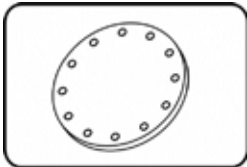

Code: 90.045

Blindflansch DIN

Blind Flange DIN

Stahl verzinkt
gebohrt PN10
Stahl verzinkt

steel galvanized
drilled PN10
steel galvanized

244

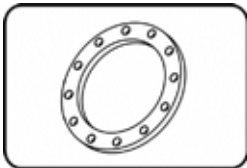

Code: 11.013

Losflansch ANSI

Backing Ring ANSI

Stahleinlage
formgespritzt
PP-GFK grau

steel insert
injection moulded
PP-FRP grey

245

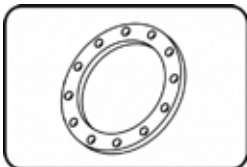

Code: 013

Losflansch ANSI

Backing Ring ANSI

Stahleinlage
formgespritzt
PP-GFK schwarz

steel insert
injection moulded
PP-FRP black

245

Product range 250 psi

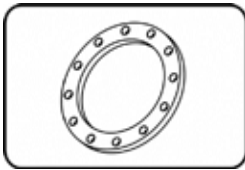

Code: 90.013

Losflansch ANSI

Stahl verzinkt
 ASME B16.5 Class 150
 Stahl verzinkt

Backing Ring ANSI

steel galvanized
 ASME B16.5 Class 150
 steel galvanized

246

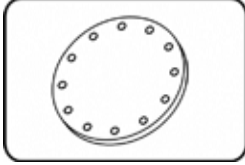

Code: 11.043

Blindflansch ANSI

Stahleinlage
 formgespritzt
 PP-GFK grau

Blind Flange ANSI

steel insert
 injection moulded
 PP-FRP grey

246

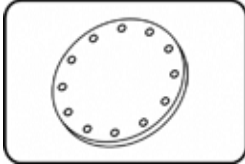

Code: 90.043

Blindflansch ANSI

Stahl verzinkt
 ASME B16.5 Class 150
 Stahl verzinkt

Blind Flange ANSI

steel galvanized
 ASME B16.5 Class 150
 steel galvanized

247

Rohr schwarz 12m

FM zugelassen

extrudiert

Pipe black 12m

FM approved

extruded

PE 100-RC schwarz

PE 100-RC black

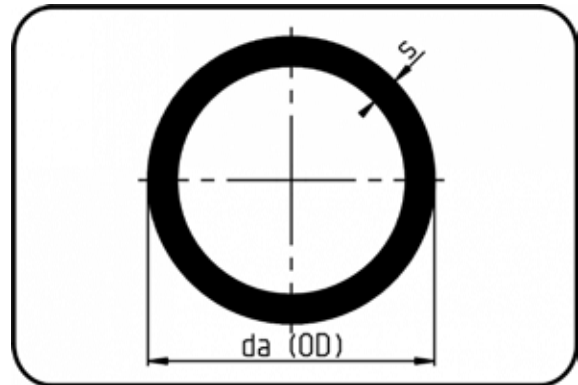

Code: 722

Dimension Dimension	Code Code	Detail Detail	da(OD) mm	s mm	Gewicht Weight
63	70.722.0063.09	63X7,1 SDR9 ISO-S4	63	7,1	1,30
75	70.722.0075.09	75x8,4 SDR9 ISO-S4	75	8,4	1,80
90	70.722.0090.09	90x10,1 SDR9 ISO-S4	90	10,1	2,60
110	70.722.0110.09	110x12,3 SDR9 ISO-S4	110	12,3	3,80
125	70.722.0125.09	125x14 SDR9 ISO-S4	125	14	4,90
140	70.722.0140.09	140x15,7 SDR9 ISO-S4	140	15,7	6,20
160	70.722.0160.09	160x17,9 SDR9 ISO-S4	160	17,9	8,04
180	70.722.0180.09	180x20,1 SDR9 ISO-S4	180	20,1	10,20
200	70.722.0200.09	200x22,4 SDR9 ISO-S4	200	22,4	12,60
225	70.722.0225.09	225x25,2 SDR9 ISO-S4	225	25,2	15,90
250	70.722.0250.09	250x27,9 SDR9 ISO-S4	250	27,9	19,56
280	70.722.0280.09	280x31,3 SDR9 ISO-S4	280	31,3	24,60
315	70.722.0315.09	315x35,2 SDR9 ISO-S4	315	35,2	31,10
355	70.722.0355.09	355x39,7 SDR9 ISO-S4	355	39,7	39,50
400	70.722.0400.09	400x44,7 SDR9 ISO-S4	400	44,7	50,10
450	70.722.0450.09	450x50,3 SDR9 ISO-S4	450	50,3	63,40
500	70.722.0500.09	500x55,8 SDR9 ISO-S4	500	55,8	78,10

Winkel 90°

lange Schenkel
SDR 7,4 ausgedreht auf SDR 9
formgespritzt+ausgedreht

**Stumpf + E-
Muffenschweissung**

PE 100-RC schwarz

Elbow 90°

long spigot
SDR 7,4 machined to SDR 9
injection moulded+chamfered

Butt + E-socket-welding

PE 100-RC black

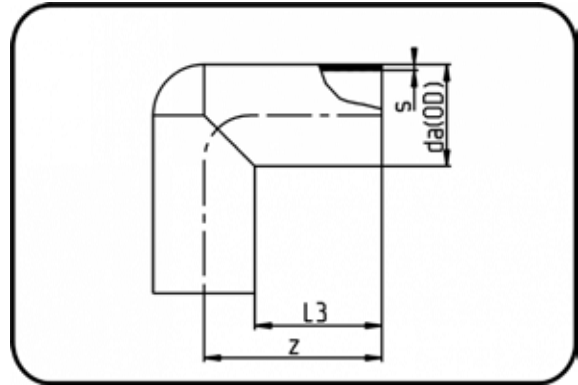

Code: 061

Dimension Dimension	Code Code	Detail Detail	da(OD) mm	s mm	z mm	L3 mm	Gewicht Weight
63	70.061.0063.09	63x7,1 SDR9 ISO S-4	63	7,1	109	76	0,31
75	70.061.0075.09	75X8,4 SDR9 ISO S-4	75	8,4	124	84,5	0,49
90	70.061.0090.09	90X10,1 SDR9 ISO S-4	90	10,1	126	82,5	0,73
110	70.061.0110.09	110X12,3 SDR9 ISO S-4	110	12,3	145,5	88	1,19
125	70.061.0125.09	125X14,0 SDR9 ISO S-4	125	14	165	101	1,74
160	70.061.0160.09	160X17,9 SDR9 ISO S-4	160	17,9	180	101	3,16
200	70.061.0200.09	200X22,4 SDR9 ISO S-4	200	22,4	214	114,5	5,75

T-Stück

lange Schenkel
SDR 7,4 ausgedreht auf SDR 9
formgespritzt+ausgedreht

**Stumpf + E-
Muffenschweissung**

PE 100-RC schwarz

Tee

long spigot
SDR 7,4 machined to SDR 9
injection moulded+chamfered

Butt + E-socket-welding

PE 100-RC black

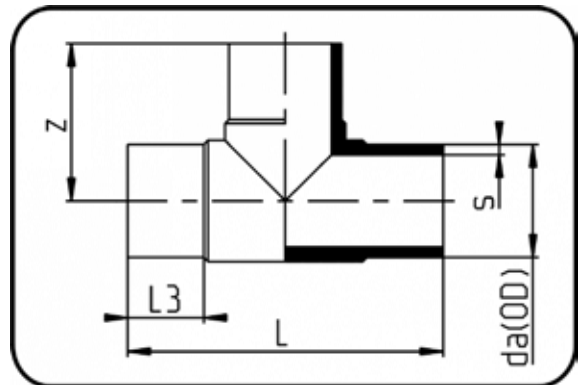

Code: 066

Dimension Dimension	Code Code	Detail Detail	da(OD) mm	s mm	z mm	L mm	L3 mm	Gewicht Weight
63	70.066.0063.09	63X7,1 SDR9 ISO S-4	63	7,1	111	219	63	0,47
90	70.066.0090.09	90x10,1 SDR9 ISO S-4	90	10,1	139	275	79	1,25
110	70.066.0110.09	110x12,3 SDR9 ISO S-4	110	12,3	158	315	82	2,04
125	70.066.0125.09	125x14,0 SDR9 ISO S-4	125	14	171,5	342	89,5	2,87
160	70.066.0160.09	160x17,9 SDR9 ISO S-4	160	17,9	203	405	99	5,28
200	70.066.0200.09	200x22,4 SDR9 ISO S-4	200	22,4	247	495	115	10,60
225	70.066.0225.09	225x25,2 SDR9 ISO S-4	225	25,2	273,5	545	120	14,20

Product range 250 psi

Endkappe

lange Schenkel
SDR 7,4 ausgedreht auf SDR 9
formgespritzt+ausgedreht

Stumpf + E-Muffenschweissung

PE 100-RC schwarz

End Cap

long spigot
SDR 7,4 machined to SDR 9
injection moulded+chamfered

Butt + E-socket-welding

PE 100-RC black

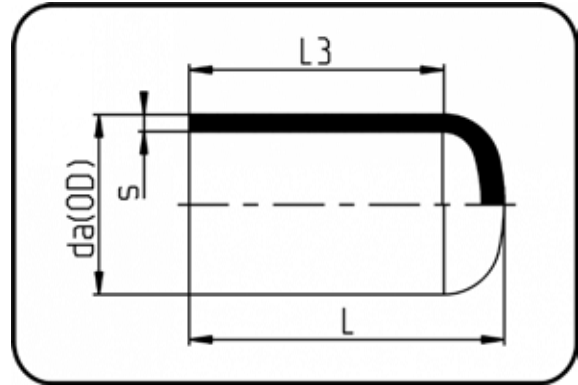

Code: 064

Dimension Dimension	Code Code	Detail Detail	da(OD) mm	s mm	L mm	L3 mm	Gewicht Weight
63	70.064.0063.09	63X7,1 SDR9 ISO S-4	63	7,1	81,5	66,5	0,12
75	70.064.0075.09	75X8,4 SDR9 ISO S-4	75	8,4	94	75	0,17
90	70.064.0090.09	90X10,1 SDR9 ISO S-4	90	10,1	100	79	0,31
110	70.064.0110.09	110X12,3 SDR9 ISO S-4	110	12,3	118	94	0,54
125	70.064.0125.09	125X14 SDR9 ISO S-4	125	14	128,5	100,5	0,76
160	70.064.0160.09	160X17,9 SDR9 ISO S-4	160	17,9	146	103,5	1,37
200	70.064.0200.09	200x22,4 SDR9 ISO S-4	200	22,4	180	121,5	2,58
225	70.064.0225.09	225X25,2 SDR9 ISO S-4	225	25,2	192	125	3,53

Vorschweissbund DIN

lange Schenkel
SDR 7,4 ausgedreht auf SDR 9
formgespritzt+ausgedreht

Stumpf + E-Muffenschweissung

PE 100-RC schwarz

Stub Flange DIN

long spigot
SDR 7,4 machined to SDR 9
injection moulded+chamfered

Butt + E-socket-welding

PE 100-RC black

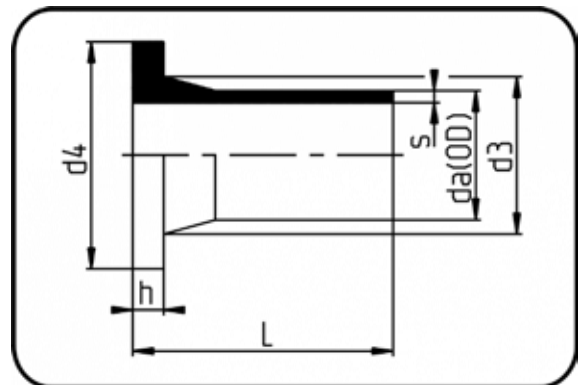

Code: 062

Dimension Dimension	Code Code	Detail Detail	da(OD) mm	s mm	L mm	d3 mm	d4 mm	h mm	Gewicht Weight
63	70.062.0063.09	63x7,1 SDR9 ISO S-4	63	7,1	118	75	102	14	0,26
75	70.062.0075.09	75x8,4 SDR9 ISO S-4	75	8,4	128	89	122	16	0,40
90	70.062.0090.09	90X10,1 SDR9 ISO S-4	90	10,1	140	105	138	17	0,59
110	70.062.0110.09	110x12,3 SDR9 ISO S-4	110	12,3	140	125	158	18	0,84
125	70.062.0125.09	125x14 SDR9 ISO S-4	125	14	180	132	158	25	1,26
160	70.062.0160.09	160x17,9 SDR9 ISO S-4	160	17,9	181,5	175	212	25	2,14
200	70.062.0200.09	200x22,4 SDR9 ISO S-4	200	22,4	180,5	232	268	32	3,58
225	70.062.0225.09	225x25,2 SDR9 ISO S-4	225	25,2	182,5	235	268	32	3,80

Flansche finden Sie bitte unter Zubehör.
Backing Rings please see Accessories.

Reduktion konzentrisch

lange Schenkel
SDR 7,4 ausgedreht auf SDR 9
formgespritzt+ausgedreht

**Stumpf + E-
Muffenschweissung**

PE 100-RC schwarz

Reducer concentric

long spigot
SDR 7,4 machined to SDR 9
injection moulded+chamfered

Butt + E-socket-welding

PE 100-RC black

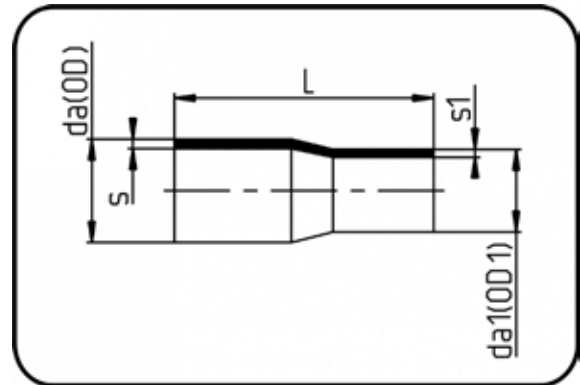

Code: 067

Dimension Dimension	Code Code	Detail Detail	da(OD) mm	da1(OD1) mm	s mm	L mm	s1 mm	Gewicht Weight
110/63	70.067.1163.09	110/63 SDR9 ISO S-4	110	63	12,3	178	7,1	0,58
110/90	70.067.1190.09	110/90 SDR9 ISO S-4	110	90	12,3	178	10,1	0,65
125/63	70.067.1263.09	125/63 SDR9 ISO S-4	125	63	14	190	7,1	0,77
125/90	70.067.1290.09	125/90 SDR9 ISO S-4	125	90	14	189	10,1	0,81
125/110	70.067.1211.09	125/110 SDR9 ISO S-4	125	110	14	197,5	12,9	0,95
160/90	70.067.1690.09	160/90 SDR9 ISO S-4	160	90	17,9	216	12,3	1,43
160/110	70.067.1611.09	160/110 SDR9 ISO S-4	160	110	17,9	223	12,3	1,52
160/125	70.067.1612.09	160/125 SDR9 ISO S-4	160	125	17,9	228	14	1,70
200/160	70.067.2016.09	200/160 SDR9 ISO S-4	200	160	22,4	251	17,9	2,88
225/160	70.067.2216.09	225/160 SDR9 ISO S-4	225	160	25,2	268	17,9	3,60
250/160	70.067.2516.09	250/160 SDR9 ISO S-4	250	160	27,9	314	17,9	2,45
250/225	70.067.2522.09	250/225 SDR9 ISO S-4	250	225	27,9	312	25,2	3,86

Product range 250 psi

Rohrbogen 11°

Radius 1,5 x da

aus Rohr geformt

**Stumpf + E-
Muffenschweissung**

PE 100-RC schwarz

Sweep Bend 11°

radius 1.5 x OD

formed out of pipe

Butt + E-socket-welding

PE 100-RC black

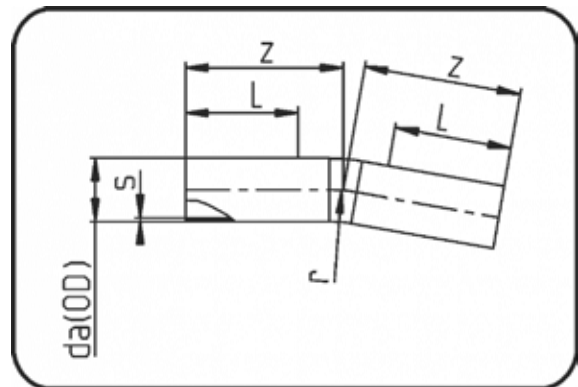

Code: 394

Dimension Dimension	Code Code	Detail Detail	da(OD) mm	s mm	z mm	r mm	L mm	Gewicht Weight
90	70.394.0090.09	90 SDR9 ISO S-4 20 bar	90	10,1	210	135	150	1,70
110	70.394.0110.09	110 SDR9 ISO S-4 20 bar	110	12,3	220	165	150	2,48
125	70.394.0125.09	125 SDR9 ISO S-4 20 bar	125	14	235	188	150	4,06
140	70.394.0140.09	140 SDR9 ISO S-4 20 bar	140	15,7	250	210	150	4,75
160	70.394.0160.09	160 SDR9 ISO S-4 20 bar	160	17,9	260	240	150	6,65
180	70.394.0180.09	180 SDR9 ISO S-4 20 bar	180	20,1	280	270	150	8,99
200	70.394.0200.09	200 SDR9 ISO S-4 20 bar	200	22,4	310	300	150	12,20
225	70.394.0225.09	225 SDR9 ISO S-4 20 bar	225	25,2	350	338	150	16,00
250	70.394.0250.09	250 SDR9 ISO S-4 20 bar	250	27,9	430	375	250	21,19
280	70.394.0280.09	280 SDR9 ISO S-4 20 bar	280	31,3	450	420	250	26,64
315	70.394.0315.09	315 SDR9 ISO S-4 20 bar	315	35,2	500	496	300	39,00
355	70.394.0355.09	355 SDR9 ISO S-4 20 bar	355	39,7	590	560	300	55,30
400	70.394.0400.09	400 SDR9 ISO S-4 20 bar	400	44,7	650	637	300	66,20
450	70.394.0450.09	450 SDR9 ISO S-4 20 bar	450	50,3	700	711	300	83,96
500	70.394.0500.09	500 SDR9 ISO S-4 20 bar	500	55,8	750	783	350	156,46

Rohrbogen 22°

Radius 1,5 x da

aus Rohr geformt

**Stumpf + E-
Muffenschweissung**

PE 100-RC schwarz

Sweep bend 22°

radius 1.5 x OD

formed out of pipe

Butt + E-socket-welding

PE 100-RC black

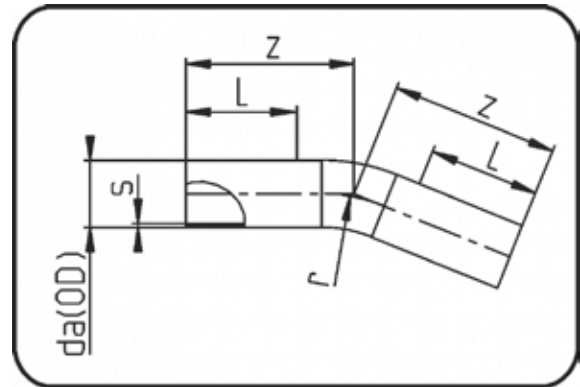

Code: 395

Dimension Dimension	Code Code	Detail Detail	da(OD) mm	s mm	z mm	r mm	L mm	Gewicht Weight
90	70.395.0090.09	90 SDR9 ISO S-4 20 bar	90	10,1	210	135	150	1,70
110	70.395.0110.09	110 SDR9 ISO S-4 20 bar	110	12,3	220	165	150	2,48
125	70.395.0125.09	125 SDR9 ISO S-4 20 bar	125	14	235	188	150	3,67
140	70.395.0140.09	140 SDR9 ISO S-4 20 bar	140	15,7	210	210	150	4,75
160	70.395.0160.09	160 SDR9 ISO S-4 20 bar	160	17,9	480	480	150	6,79
180	70.395.0180.09	180 SDR9 ISO S-4 20 bar	180	20,1	280	270	150	8,99
200	70.395.0200.09	200 SDR9 ISO S-4 20 bar	200	22,4	310	300	150	12,20
225	70.395.0225.09	225 SDR9 ISO S-4 20 bar	225	25,2	350	338	150	16,00
250	70.395.0250.09	250 SDR9 ISO S-4 20 bar	250	27,9	430	375	250	21,19
280	70.395.0280.09	280 SDR9 ISO S-4 20 bar	280	31,3	450	420	250	26,64
315	70.395.0315.09	315 SDR9 ISO S-4 20 bar	315	35,2	500	496	300	39,00
355	70.395.0355.09	355 SDR9 ISO S-4 20 bar	355	39,7	590	560	300	55,30
400	70.395.0400.09	400 SDR9 ISO S-4 20 bar	400	44,7	650	637	300	66,20
450	70.395.0450.09	450 SDR9 ISO S-4 20 bar	450	50,3	700	711	300	83,69
500	70.395.0500.09	500 SDR9 ISO S-4 20 bar	500	55,8	750	783	350	156,46

Product range 250 psi

Rohrbogen 30°

Radius 1,5 x da

aus Rohr geformt

**Stumpf + E-
Muffenschweissung**

PE 100-RC schwarz

Sweep Bend 30°

radius 1.5 x OD

formed out of pipe

Butt + E-socket-welding

PE 100-RC black

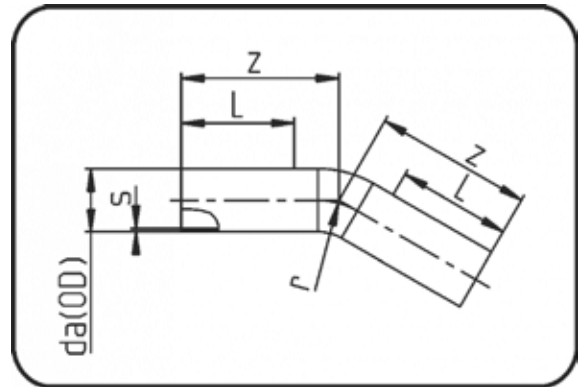

Code: 396

Dimension Dimension	Code Code	Detail Detail	da(OD) mm	s mm	z mm	r mm	L mm	Gewicht Weight
90	70.396.0090.09	90 SDR9 ISO S-4 20 bar	90	10,1	210	135	150	1,70
110	70.396.0110.09	110 SDR9 ISO S-4 20 bar	110	12,3	220	165	150	2,48
125	70.396.0125.09	125 SDR9 ISO S-4 20 bar	125	14	235	188	150	3,67
140	70.396.0140.09	140 SDR9 ISO S-4 20 bar	140	15,7	250	210	150	4,75
160	70.396.0160.09	160 SDR9 ISO S-4 20 bar	160	17,9	260	240	150	6,65
180	70.396.0180.09	180 SDR9 ISO S-4 20 bar	180	20,1	280	270	150	8,99
200	70.396.0200.09	200 SDR9 ISO S-4 20 bar	200	22,4	310	300	150	11,86
225	70.396.0225.09	225 SDR9 ISO S-4 20 bar	225	25,2	350	338	150	12,63
250	70.396.0250.09	250 SDR9 ISO S-4 20 bar	250	27,9	430	375	250	21,19
280	70.396.0280.09	280 SDR9 ISO S-4 20 bar	280	31,3	450	420	250	26,64
315	70.396.0315.09	315 SDR9 ISO S-4 20 bar	315	35,2	500	496	300	39,00
355	70.396.0355.09	355 SDR9 ISO S-4 20 bar	355	39,7	590	560	300	51,28
400	70.396.0400.09	400 SDR9 ISO S-4 20 bar	400	44,7	650	637	300	69,11
450	70.396.0450.09	450 SDR9 ISO S-4 20 bar	450	50,3	700	711	300	92,57
500	70.396.0500.09	500 SDR9 ISO S-4 20 bar	500	55,8	750	783	350	135,72

Rohrbogen 45°

Radius 1,5 x da

aus Rohr geformt

**Stumpf + E-
Muffenschweissung**

PE 100-RC schwarz

Sweep Bend 45°

radius 1.5 x OD

formed out of pipe

Butt + E-socket-welding

PE 100-RC black

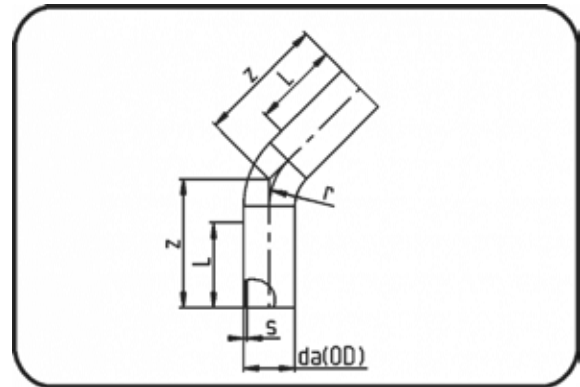

Code: 397

Dimension Dimension	Code Code	Detail Detail	da(OD) mm	s mm	z mm	r mm	L mm	Gewicht Weight
90	70.397.0090.09	90 SDR9 ISO S-4 20 bar	90	10,1	220	135	150	1,30
110	70.397.0110.09	110 SDR9 ISO S-4 20 bar	110	12,3	240	165	150	2,10
125	70.397.0125.09	125 SDR9 ISO S-4 20 bar	125	14	250	188	150	3,67
140	70.397.0140.09	140 SDR9 ISO S-4 20 bar	140	15,7	270	210	150	4,75
160	70.397.0160.09	160 SDR9 ISO S-4 20 bar	160	17,9	330	240	150	6,30
180	70.397.0180.09	180 SDR9 ISO S-4 20 bar	180	20,1	350	270	150	8,99
200	70.397.0200.09	200 SDR9 ISO S-4 20 bar	200	22,4	360	300	150	12,20
225	70.397.0225.09	225 SDR9 ISO S-4 20 bar	225	25,2	380	338	150	12,70
250	70.397.0250.09	250 SDR9 ISO S-4 20 bar	250	27,9	490	375	250	19,50
280	70.397.0280.09	280 SDR9 ISO S-4 20 bar	280	31,3	510	420	250	26,64
315	70.397.0315.09	315 SDR9 ISO S-4 20 bar	315	35,2	560	496	300	46,65
355	70.397.0355.09	355 SDR9 ISO S-4 20 bar	355	39,7	630	560	300	59,25
400	70.397.0400.09	400 SDR9 ISO S-4 20 bar	400	44,7	670	637	300	70,20
450	70.397.0450.09	450 SDR9 ISO S-4 20 bar	450	50,3	750	711	300	99,12
500	70.397.0500.09	500 SDR9 ISO S-4 20 bar	500	55,8	900	783	350	135,72

Product range 250 psi

Rohrbogen 60°

Radius 1,5 x da

aus Rohr geformt

**Stumpf + E-
Muffenschweissung**

PE 100-RC schwarz

Sweep Bend 60°

radius 1.5 x OD

formed out of pipe

Butt + E-socket-welding

PE 100-RC black

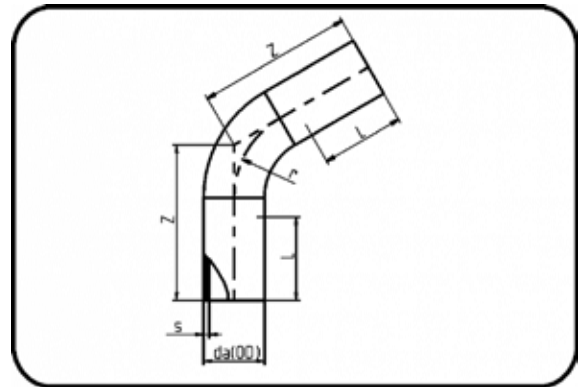

Code: 398

Dimension Dimension	Code Code	Detail Detail	da(OD) mm	s mm	z mm	r mm	L mm	Gewicht Weight
90	70.398.0090.09	90 SDR9 ISO S-4 20 bar	90	10,1	250	135	150	1,54
110	70.398.0110.09	110 SDR9 ISO S-4 20 bar	110	12,3	280	165	150	2,48
125	70.398.0125.09	125 SDR9 ISO S-4 20 bar	125	14	300	188	150	3,46
140	70.398.0140.09	140 SDR9 ISO S-4 20 bar	140	15,7	350	210	150	5,54
160	70.398.0160.09	160 SDR9 ISO S-4 20 bar	160	17,9	380	240	150	6,86
180	70.398.0180.09	180 SDR9 ISO S-4 20 bar	180	20,1	410	270	150	10,21
200	70.398.0200.09	200 SDR9 ISO S-4 20 bar	200	22,4	430	300	150	12,22
225	70.398.0225.09	225 SDR9 ISO S-4 20 bar	225	25,2	450	338	150	16,61
250	70.398.0250.09	250 SDR9 ISO S-4 20 bar	250	27,9	570	375	250	27,38
280	70.398.0280.09	280 SDR9 ISO S-4 20 bar	280	31,3	580	420	250	34,44
315	70.398.0315.09	315 SDR9 ISO S-4 20 bar	315	35,2	690	496	300	52,84
355	70.398.0355.09	355 SDR9 ISO S-4 20 bar	355	39,7	760	560	300	71,00
400	70.398.0400.09	400 SDR9 ISO S-4 20 bar	400	44,7	780	637	300	100,15
450	70.398.0450.09	450 SDR9 ISO S-4 20 bar	450	50,3	820	711	300	141,10
500	70.398.0500.09	500 SDR9 ISO S-4 20 bar	500	55,8	960	783	350	203,39

Rohrbogen 90 °

Radius 1,5 x da

aus Rohr geformt

**Stumpf + E-
Muffenschweissung**

PE 100-RC schwarz

Sweep Bend 90°

radius 1.5 x OD

formed out of pipe

Butt + E-socket-welding

PE 100-RC black

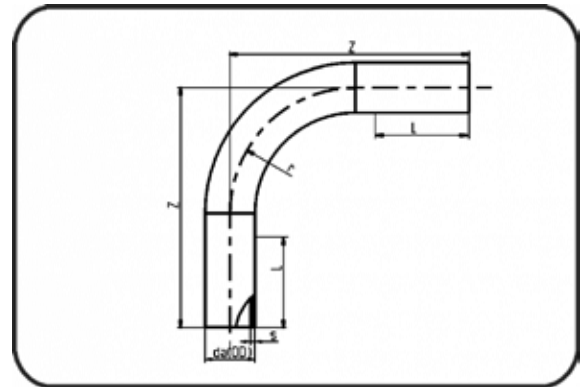

Code: 399

Dimension Dimension	Code Code	Detail Detail	da(OD) mm	s mm	z mm	r mm	L mm	Gewicht Weight
90	70.399.0090.09	90 SDR9 ISO S-4 20 bar	90	10,1	300	135	150	1,56
110	70.399.0110.09	110 SDR9 ISO S-4 20 bar	110	12,3	380	165	150	2,87
125	70.399.0125.09	125 SDR9 ISO S-4 20 bar	125	14	400	188	150	3,67
140	70.399.0140.09	140 SDR9 ISO S-4 20 bar	140	15,7	440	210	150	5,71
160	70.399.0160.09	160 SDR9 ISO S-4 20 bar	160	17,9	480	240	150	6,79
180	70.399.0180.09	180 SDR9 ISO S-4 20 bar	180	20,1	530	270	150	10,91
200	70.399.0200.09	200 SDR9 ISO S-4 20 bar	200	22,4	560	300	150	11,90
225	70.399.0225.09	225 SDR9 ISO S-4 20 bar	225	25,2	590	338	150	16,30
250	70.399.0250.09	250 SDR9 ISO S-4 20 bar	250	27,9	730	375	250	25,50
280	70.399.0280.09	280 SDR9 ISO S-4 20 bar	280	31,3	750	420	250	33,00
315	70.399.0315.09	315 SDR9 ISO S-4 20 bar	315	35,2	900	496	300	55,98
355	70.399.0355.09	355 SDR9 ISO S-4 20 bar	355	39,7	1.000	560	300	75,05
400	70.399.0400.09	400 SDR9 ISO S-4 20 bar	400	44,7	1.050	637	300	94,32
450	70.399.0450.09	450 SDR9 ISO S-4 20 bar	450	50,3	1.150	711	300	133,44
500	70.399.0500.09	500 SDR9 ISO S-4 20 bar	500	55,8	1.300	783	350	183,12

T-Stück

kurze Schenkel

mechanisch gefertigt

Stumpfschweissung

PE 100-RC schwarz

Tee

short spigot

machined

Butt-welding

PE 100-RC black

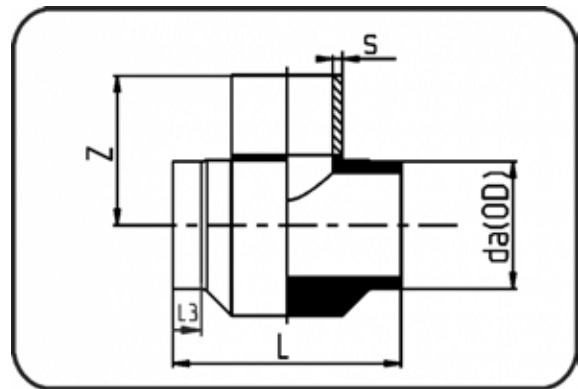

Code: 307.1

Dimension Dimension	Code Code	Detail Detail	da(OD) mm	s mm	z mm	L3 mm	d1 mm	L mm	Gewicht Weight
250	70.307.2525.09	250 SDR9 ISO S-4	250	27,9	355	75	355	450	21,20
280	70.307.2828.09	280 SDR9 ISO S-4	280	31,3	370	75	390	480	26,22
315	70.307.3131.09	315 SDR9 ISO S-4	315	35,2	337,5	75	430	520	37,50
355	70.307.3535.09	355 SDR9 ISO S-4	355	39,7	457,5	75	480	560	35,00
400	70.307.4040.09	400 SDR9 ISO S-4	400	44,7	530	75	540	600	76,70
450	70.307.4545.09	450 SDR9 ISO S-4	450	50,3	555	75	600	650	45,20
500	70.307.5050.09	500 SDR9 ISO S-4	500	55,8	580	75	660	710	45,60

T-Stück reduziert

kurze Schenkel

mechanisch gefertigt

Stumpfschweissung

PE 100-RC schwarz

Tee reduced

short spigot

machined

Butt-welding

PE 100-RC black

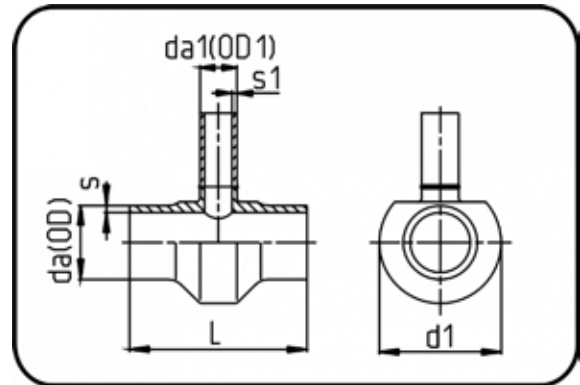

Code: 307

Dimension Dimension	Code Code	Detail Detail	da(OD) mm	da1(OD1) mm	s mm	s1 mm	d1 mm	L mm	Gewicht Weight
90/63	70.307.9063.09	90/63 SDR9 ISO S-4	90	63	10,1	7,1	154	213	1,30
90/75	70.307.9075.09	90/75 SDR9 ISO S-4	90	75	10,1	8,4	159	225	1,60
110/63	70.307.1163.09	110/63 SDR9 ISO S-4	110	63	12,3	7,1	172	213	2,01
110/75	70.307.1175.09	110/75 SDR9 ISO S-4	110	75	12,3	8,4	177	255	2,20
110/90	70.307.1190.09	110/90 SDR9 ISO S-4	110	90	12,3	10,1	184	240	2,30
125/63	70.307.1263.09	125/63 SDR9 ISO S-4	125	63	14	7,1	186	213	2,80
125/75	70.307.1275.09	125/75 SDR9 ISO S-4	125	75	14	8,4	191	225	2,80
125/90	70.307.1290.09	125/90 SDR9 ISO S-4	125	90	14	10,1	197	240	3,00
140/63	70.307.1463.09	140/63 SDR9 ISO S-4	140	63	15,7	7,1	201	213	3,50
140/75	70.307.1475.09	140/75 SDR9 ISO S-4	140	75	15,7	8,4	205	225	3,20
140/90	70.307.1490.09	140/90 SDR9 ISO S-4	140	90	15,7	10,1	211	240	3,80
140/110	70.307.1411.09	140/110 SDR9 ISO S-4	140	110	15,7	12,3	220	260	4,10
140/125	70.307.1412.09	140/125 SDR9 ISO S-4	140	125	15,7	14	228	275	4,40
160/63	70.307.1663.09	160/63 SDR9 ISO S-4	160	63	17,9	7,1	220	213	5,00
160/75	70.307.1675.09	160/75 SDR9 ISO S-4	160	75	17,9	8,4	223	225	5,20
160/90	70.307.1690.09	160/90 SDR9 ISO S-4	160	90	17,9	10,1	229	240	5,40
160/110	70.307.1611.09	160/110 SDR9 ISO S-4	160	110	17,9	12,3	238	260	4,72
160/125	70.307.1612.09	160/125 SDR9 ISO S-4	160	125	17,9	14	245	275	5,80
180/63	70.307.1863.09	180/63 SDR9 ISO S-4	180	63	20,1	7,1	239	213	6,40
180/75	70.307.1875.09	180/75 SDR9 ISO S-4	180	75	20,1	8,4	242	225	4,50
180/90	70.307.1890.09	180/90 SDR9 ISO S-4	180	90	20,1	10,1	247	240	7,00
180/110	70.307.1811.09	180/110 SDR9 ISO S-4	180	110	20,1	12,3	255	260	7,70
180/125	70.307.1812.09	180/125 SDR9 ISO S-4	180	125	20,1	14	262	275	8,00
200/63	70.307.2063.09	200/63 SDR9 ISO S-4	200	63	22,4	7,1	258	213	8,20
200/75	70.307.2075.09	200/75 SDR9 ISO S-4	200	75	22,4	8,4	262	225	6,80
200/90	70.307.2090.09	200/90 SDR9 ISO S-4	200	90	22,4	10,1	266	240	8,50
200/110	70.307.2011.09	200/110 SDR9 ISO S-4	200	110	22,4	12,3	274	260	8,80
200/125	70.307.2012.09	200/125 SDR9 ISO S-4	200	125	22,4	14	280	275	9,00
200/140	70.307.2014.09	200/140 SDR9 ISO S-4	200	140	22,4	15,7	287	290	9,30
200/160	70.307.2016.09	200/160 SDR9 ISO S-4	200	160	22,4	17,9	297	310	9,70
225/63	70.307.2263.09	225/63 SDR9 ISO S-4	225	63	25,2	7,1	283	213	11,00
225/75	70.307.2275.09	225/75 SDR9 ISO S-4	225	75	25,2	8,4	286	225	8,90
225/90	70.307.2290.09	225/90 SDR9 ISO S-4	225	90	25,2	10,1	290	240	12,00

Product range 250 psi

T-Stück reduziert

kurze Schenkel

mechanisch gefertigt

Stumpfschweissung

PE 100-RC schwarz

Tee reduced

short spigot

machined

Butt-welding

PE 100-RC black

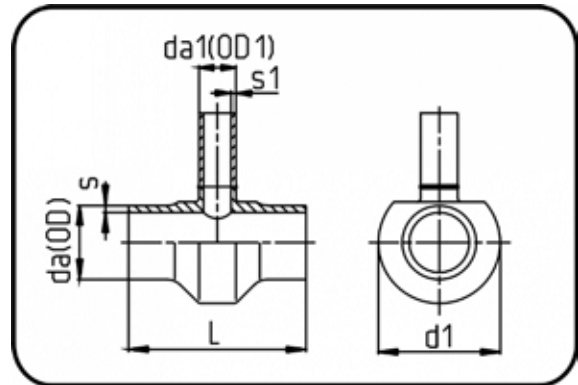

Code: 307

Dimension Dimension	Code Code	Detail Detail	da(OD) mm	da1(OD1) mm	s mm	s1 mm	d1 mm	L mm	Gewicht Weight
225/110	70.307.2211.09	225/110 SDR9 ISO S-4	225	110	25,2	12,3	297	260	13,00
225/125	70.307.2212.09	225/125 SDR9 ISO S-4	225	125	25,2	14	303	275	14,00
225/140	70.307.2214.09	225/140 SDR9 ISO S-4	225	140	25,2	15,7	309	209	13,50
225/160	70.307.2216.09	225/160 SDR9 ISO S-4	225	160	25,2	17,9	318	310	14,50
250/63	70.307.2563.09	250/63 SDR9 ISO S-4	250	63	27,9	7,1	307	213	15,00
250/75	70.307.2575.09	250/75 SDR9 ISO S-4	250	75	27,9	8,4	340	225	15,50
250/90	70.307.2590.09	250/90 SDR9 ISO S-4	250	90	27,9	10,1	314	240	16,00
250/110	70.307.2511.09	250/110 SDR9 ISO S-4	250	110	27,9	12,3	320	260	17,00
250/125	70.307.2512.09	250/125 SDR9 ISO S-4	250	125	27,9	14	325	275	17,00
250/140	70.307.2514.09	250/140 SDR9 ISO S-4	250	140	27,9	15,7	332	290	18,00
250/160	70.307.2516.09	250/160 SDR9 ISO S-4	250	160	27,9	17,9	340	310	19,00
250/180	70.307.2518.09	250/180 SDR9 ISO S-4	250	180	27,9	20,1	350	330	20,00
280/63	70.307.2863.09	280/63 SDR9 ISO S-4	280	63	31,3	7,1	336	213	18,00
280/75	70.307.2875.09	280/75 SDR9 ISO S-4	280	75	31,3	8,4	339	225	19,00
280/90	70.307.2890.09	280/90 SDR9 ISO S-4	280	90	31,3	10,1	343	240	19,00
280/110	70.307.2811.09	280/110 SDR9 ISO S-4	280	110	31,3	12,3	348	260	20,00
280/125	70.307.2812.09	280/125 SDR9 ISO S-4	280	125	31,3	14	353	275	21,00
280/140	70.307.2814.09	280/140 SDR9 ISO S-4	280	140	31,3	15,7	359	290	23,00
280/160	70.307.2816.09	280/160 SDR9 ISO S-4	280	160	31,3	17,9	367	310	24,00
280/180	70.307.2818.09	280/180 SDR9 ISO S-4	280	180	31,3	20,1	376	330	25,00
280/200	70.307.2820.09	280/200 SDR9 ISO S-4	280	200	31,3	22,4	386	350	28,00
315/63	70.307.3163.09	315/63 SDR9 ISO S-4	315	63	35,2	7,1	371	213	22,00
315/75	70.307.3175.09	315/75 SDR9 ISO S-4	315	75	35,2	8,4	373	225	26,00
315/90	70.307.3190.09	315/90 SDR9 ISO S-4	315	90	35,2	10,1	376	240	23,00
315/110	70.307.3111.09	315/110 SDR9 ISO S-4	315	110	35,2	12,3	382	260	11,40
315/140	70.307.3114.09	315/140 SDR9 ISO S-4	315	140	35,2	15,7	391	290	29,00
315/160	70.307.3116.09	315/160 SDR9 ISO S-4	315	160	35,2	17,9	399	310	24,70
315/180	70.307.3118.09	315/180 SDR9 ISO S-4	315	180	35,2	20,1	407	330	25,70
315/200	70.307.3120.09	315/200 SDR9 ISO S-4	315	200	35,2	22,4	417	350	24,90
315/225	70.307.3122.09	315/225 SDR9 ISO S-4	315	225	35,2	25,2	429	375	25,00
355/63	70.307.3563.09	355/63 SDR9 ISO S-4	355	63	39,7	7,1	410	263	27,80
355/75	70.307.3575.09	355/75 SDR9 ISO S-4	355	75	39,7	8,4	412	275	30,00
355/90	70.307.3590.09	355/90 SDR9 ISO S-4	355	90	39,7	10,1	415	290	28,20

T-Stück reduziert

kurze Schenkel

mechanisch gefertigt

Stumpfschweissung

PE 100-RC schwarz

Tee reduced

short spigot

machined

Butt-welding

PE 100-RC black

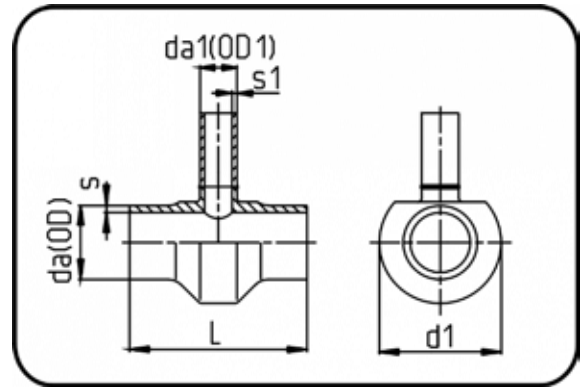

Code: 307

Dimension Dimension	Code Code	Detail Detail	da(OD) mm	da1(OD1) mm	s mm	s1 mm	d1 mm	L mm	Gewicht Weight
355/110	70.307.3511.09	355/110 SDR9 ISO S-4	355	110	39,7	12,3	420	310	29,00
355/140	70.307.3514.09	355/140 SDR9 ISO S-4	355	140	39,7	15,7	429	340	33,00
355/160	70.307.3516.09	355/160 SDR9 ISO S-4	355	160	39,7	17,9	436	360	29,80
355/180	70.307.3518.09	355/180 SDR9 ISO S-4	355	180	39,7	20,1	444	380	30,60
355/200	70.307.3520.09	355/200 SDR9 ISO S-4	355	200	39,7	22,4	452	400	34,00
355/225	70.307.3522.09	355/225 SDR9 ISO S-4	355	225	39,7	25,2	464	425	35,00
355/250	70.307.3525.09	355/250 SDR9 ISO S-4	355	250	39,7	27,9	476	450	36,00
400/63	70.307.4063.09	400/63 SDR9 ISO S-4	400	63	44,7	7,1	455	263	33,50
400/75	70.307.4075.09	400/75 SDR9 ISO S-4	400	75	44,7	8,4	457	275	34,00
400/90	70.307.4090.09	400/90 SDR9 ISO S-4	400	90	44,7	10,1	459	290	17,80
400/110	70.307.4011.09	400/110 SDR9 ISO S-4	400	110	44,7	12,3	464	310	35,70
400/160	70.307.4016.09	400/160 SDR9 ISO S-4	400	160	44,7	17,9	478	360	38,90
400/180	70.307.4018.09	400/180 SDR9 ISO S-4	400	180	44,7	20,1	485	380	41,00
400/200	70.307.4020.09	400/200 SDR9 ISO S-4	400	200	44,7	22,4	493	400	30,90
400/225	70.307.4022.09	400/225 SDR9 ISO S-4	400	225	44,7	25,2	504	425	39,00
400/250	70.307.4025.09	400/250 SDR9 ISO S-4	400	250	44,7	27,9	515	450	40,00
400/280	70.307.4028.09	400/280 SDR9 ISO S-4	400	280	44,7	31,3	530	480	41,00
400/315	70.307.4031.09	400/315 SDR9 ISO S-4	400	315	44,7	35,2	550	515	43,00
450/63	70.307.4563.09	450/63 SDR9 ISO S-4	450	63	50,3	7,1	504	263	40,50
450/75	70.307.4575.09	450/75 SDR9 ISO S-4	450	75	50,3	8,4	506	275	37,00
450/90	70.307.4590.09	450/90 SDR9 ISO S-4	450	90	50,3	10,1	509	290	38,00
450/110	70.307.4511.09	450/110 SDR9 ISO S-4	450	110	50,3	12,3	512	310	41,20
450/125	70.307.4512.09	450/125 SDR9 ISO S-4	450	125	50,3	14	516	325	39,00
450/140	70.307.4514.09	450/140 SDR9 ISO S-4	450	140	50,3	15,7	520	340	40,00
450/160	70.307.4516.09	450/160 SDR9 ISO S-4	450	160	50,3	17,9	525	360	42,00
450/180	70.307.4518.09	450/180 SDR9 ISO S-4	450	180	50,3	20,1	532	380	42,70
450/200	70.307.4520.09	450/200 SDR9 ISO S-4	450	200	50,3	22,4	539	400	37,20
450/225	70.307.4522.09	450/225 SDR9 ISO S-4	450	225	50,3	25,2	549	425	42,00
450/250	70.307.4525.09	450/250 SDR9 ISO S-4	450	250	50,3	27,9	560	450	50,00
450/280	70.307.4528.09	450/280 SDR9 ISO S-4	450	280	50,3	31,3	574	480	43,00
450/315	70.307.4531.09	450/315 SDR9 ISO S-4	450	315	50,3	35,2	591	515	65,10
500/63	70.307.5063.09	500/63 SDR9 ISO S-4	500	63	55,8	7,1	554	293	42,70
500/75	70.307.5075.09	500/75 SDR9 ISO S-4	500	75	55,8	8,4	556	275	41,00

Product range 250 psi

T-Stück reduziert

kurze Schenkel

mechanisch gefertigt

Stumpfschweissung

PE 100-RC schwarz

Tee reduced

short spigot

machined

Butt-welding

PE 100-RC black

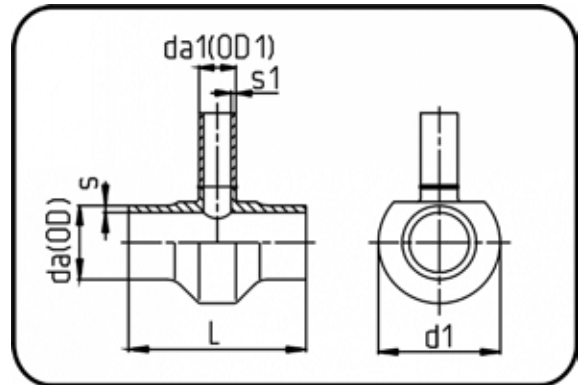

Code: 307

Dimension Dimension	Code Code	Detail Detail	da(OD) mm	da1(OD1) mm	s mm	s1 mm	d1 mm	L mm	Gewicht Weight
500/90	70.307.5090.09	500/90 SDR9 ISO S-4	500	90	55,8	10,1	558	290	42,00
500/110	70.307.5011.09	500/110 SDR9 ISO S-4	500	110	55,8	12,3	561	340	43,40
500/125	70.307.5012.09	500/125 SDR9 ISO S-4	500	125	55,8	14	565	325	43,00
500/140	70.307.5014.09	500/140 SDR9 ISO S-4	500	140	55,8	15,7	568	340	44,00
500/160	70.307.5016.09	500/160 SDR9 ISO S-4	500	160	55,8	17,9	573	390	44,00
500/180	70.307.5018.09	500/180 SDR9 ISO S-4	500	180	55,8	20,1	579	410	44,50
500/200	70.307.5020.09	500/200 SDR9 ISO S-4	500	200	55,8	22,4	586	430	44,70
500/225	70.307.5022.09	500/225 SDR9 ISO S-4	500	225	55,8	25,2	595	455	45,00
500/250	70.307.5025.09	500/250 SDR9 ISO S-4	500	250	55,8	27,9	605	450	46,00
500/280	70.307.5028.09	500/280 SDR9 ISO S-4	500	280	55,8	31,3	618	480	47,00

Reduktion konzentrisch

kurze Schenkel

mechanisch gefertigt

Stumpfschweissung

PE 100-RC schwarz

Reducer concentric

short spigot

machined

Butt-welding

PE 100-RC black

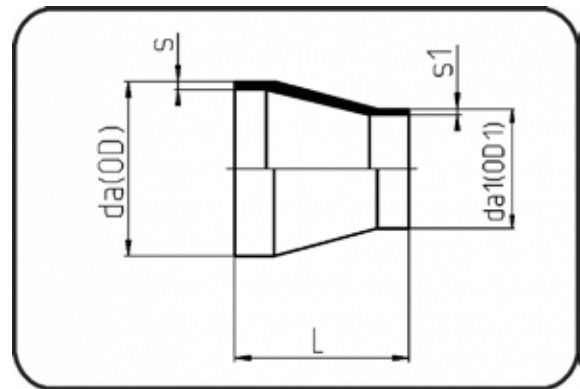

Code: 317

Dimension Dimension	Code Code	Detail Detail	da(OD) mm	da1(OD1) mm	s mm	L mm	s1 mm	Gewicht Weight
75/63	70.317.7563.09	75/63 SDR9 ISO S-4	75	63	8,4	70	7,1	0,12
90/50	70.317.9050.09	90/50 SDR9 ISO S-4	90	50	10,1	70	5,6	0,16
90/63	70.317.9063.09	90/63 SDR9 ISO S-4	90	63	10,1	70	7,1	0,16
90/75	70.317.9075.09	90/75 SDR9 ISO S-4	90	75	10,1	70	8,4	0,17
110/50	70.317.1150.09	110/50 SDR9 ISO S-4	110	50	12,3	95	5,6	0,28
110/63	70.317.1163.09	110/63 SDR9 ISO S-4	110	63	12,3	95	7,1	0,28
110/75	70.317.1175.09	110/75 SDR9 ISO S-4	110	75	12,3	95	8,4	0,29
110/90	70.317.1190.09	110/90 SDR9 ISO S-4	110	90	12,3	95	10,1	0,34
125/63	70.317.1263.09	125/63 SDR9 ISO S-4	125	63	14	95	7,1	0,45
125/75	70.317.1275.09	125/75 SDR9 ISO S-4	125	75	14	95	8,4	0,54
125/90	70.317.1290.09	125/90 SDR9 ISO S-4	125	90	14	95	10,1	0,50
125/110	70.317.1211.09	125/110 SDR9 ISO S-4	125	110	14	95	12,3	0,53
140/75	70.317.1475.09	140/75 SDR9 ISO S-4	140	75	15,7	115	8,4	0,61
140/90	70.317.1490.09	140/90 SDR9 ISO S-4	140	90	15,7	115	10,1	0,63
140/110	70.317.1411.09	140/110 SDR9 ISO S-4	140	110	15,7	115	12,3	0,59
140/125	70.317.1412.09	140/125 SDR9 ISO S-4	140	125	15,7	115	14	0,57
160/90	70.317.1690.09	160/90 SDR9 ISO S-4	160	90	17,9	115	10,1	0,67
160/110	70.317.1611.09	160/110 SDR9 ISO S-4	160	110	17,9	115	12,3	0,75
160/125	70.317.1612.09	160/125 SDR9 ISO S-4	160	125	17,9	125	14	0,89
160/140	70.317.1614.09	160/140 SDR9 ISO S-4	160	140	17,9	125	15,7	0,87
180/90	70.317.1890.09	180/90 SDR9 ISO S-4	180	90	20,1	140	10,1	1,35
180/110	70.317.1811.09	180/110 SDR9 ISO S-4	180	110	20,1	135	12,3	1,40
180/125	70.317.1812.09	180/125 SDR9 ISO S-4	180	125	20,1	130	14	1,05
180/140	70.317.1814.09	180/140 SDR9 ISO S-4	180	140	20,1	130	15,7	1,38
180/160	70.317.1816.09	180/160 SDR9 ISO S-4	180	160	20,1	125	17,9	1,32
200/140	70.317.2014.09	200/140 SDR9 ISO S-4	200	140	22,4	145	15,7	1,44
200/160	70.317.2016.09	200/160 SDR9 ISO S-4	200	160	22,4	140	17,9	1,60
200/180	70.317.2018.09	200/180 SDR9 ISO S-4	200	180	22,4	140	20,1	1,86
225/140	70.317.2214.09	225/140 SDR9 ISO S-4	225	140	25,2	155	15,7	2,15
225/160	70.317.2216.09	225/160 SDR9 ISO S-4	225	160	25,2	150	17,9	2,20
225/180	70.317.2218.09	225/180 SDR9 ISO S-4	225	180	25,2	145	20,1	3,10
225/200	70.317.2220.09	225/200 SDR9 ISO S-4	225	200	25,2	140	22,4	3,75
250/180	70.317.2518.09	250/180 SDR9 ISO S-4	250	180	27,9	160	20,1	5,00

Product range 250 psi

Reduktion konzentrisch

kurze Schenkel

mechanisch gefertigt

Stumpfschweissung

PE 100-RC schwarz

Reducer concentric

short spigot

machined

Butt-welding

PE 100-RC black

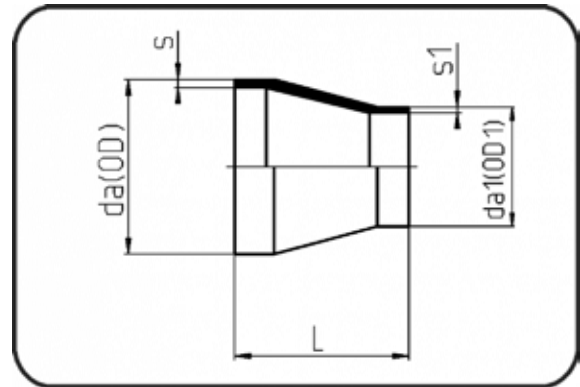

Code: 317

Dimension Dimension	Code Code	Detail Detail	da(OD) mm	da1(OD1) mm	s mm	L mm	s1 mm	Gewicht Weight
250/200	70.317.2520.09	250/200 SDR9 ISO S-4	250	200	27,9	200	22,4	3,60
280/160	70.317.2816.09	280/160 SDR9 ISO S-4	280	160	31,3	200	17,9	3,50
280/180	70.317.2818.09	280/180 SDR9 ISO S-4	280	180	31,3	160	20,1	7,00
280/200	70.317.2820.09	280/200 SDR9 ISO S-4	280	200	31,3	200	22,4	3,80
280/225	70.317.2822.09	280/225 SDR9 ISO S-4	280	225	31,3	200	25,5	4,60
280/250	70.317.2825.09	280/250 SDR9 ISO S-4	280	250	31,3	200	27,9	4,30
315/160	70.317.3116.09	315/160 SDR9 ISO S-4	315	160	35,2	200	17,9	4,98
315/180	70.317.3118.09	315/180 SDR9 ISO S-4	315	180	35,2	200	20,1	4,60
315/225	70.317.3122.09	315/225 SDR9 ISO S-4	315	225	35,2	200	25,5	5,20
315/250	70.317.3125.09	315/250 SDR9 ISO S-4	315	250	35,2	200	27,9	5,80
315/280	70.317.3128.09	315/280 SDR9 ISO S-4	315	280	35,2	200	31,3	6,00
355/180	70.317.3518.09	355/180 SDR9 ISO S-4	355	180	39,7	250	20,1	8,00
355/200	70.317.3520.09	355/200 SDR9 ISO S-4	355	200	39,7	210	22,4	9,00
355/225	70.317.3522.09	355/225 SDR9 ISO S-4	355	225	39,7	250	25,5	8,60
355/250	70.317.3525.09	355/250 SDR9 ISO S-4	355	250	39,7	250	27,9	8,80
355/280	70.317.3528.09	355/280 SDR9 ISO S-4	355	280	39,7	250	31,3	9,20
355/315	70.317.3531.09	355/315 SDR9 ISO S-4	355	315	39,7	250	35,2	9,60
400/180	70.317.4018.09	400/180 SDR9 ISO S-4	400	180	44,7	250	20,1	9,60
400/225	70.317.4022.09	400/225 SDR9 ISO S-4	400	225	44,7	250	25,5	9,00
400/250	70.317.4025.09	400/250 SDR9 ISO S-4	400	250	44,7	250	27,9	10,40
400/280	70.317.4028.09	400/280 SDR9 ISO S-4	400	280	44,7	250	31,3	10,80
400/315	70.317.4031.09	400/315 SDR9 ISO S-4	400	315	44,7	250	35,2	11,40
400/355	70.317.4035.09	400/355 SDR9 ISO S-4	400	355	44,7	250	39,7	11,80
450/225	70.317.4522.09	450/225 SDR9 ISO S-4	450	225	50,3	250	25,5	14,00
450/250	70.317.4525.09	450/250 SDR9 ISO S-4	450	250	50,3	250	27,9	7,07
450/280	70.317.4528.09	450/280 SDR9 ISO S-4	450	280	50,3	250	31,3	14,80
450/315	70.317.4531.09	450/315 SDR9 ISO S-4	450	315	50,3	250	35,2	14,20
450/355	70.317.4535.09	450/355 SDR9 ISO S-4	450	355	50,3	250	39,7	16,00
450/400	70.317.4540.09	450/400 SDR9 ISO S-4	450	400	50,3	250	44,7	16,50
500/315	70.317.5031.09	500/315 SDR9 ISO S-4	500	315	55,8	250	35,2	17,40
500/355	70.317.5035.09	500/355 SDR9 ISO S-4	500	355	55,8	250	39,7	17,40
500/400	70.317.5040.09	500/400 SDR9 ISO S-4	500	400	55,8	250	44,7	18,00
500/450	70.317.5045.09	500/450 SDR9 ISO S-4	500	450	55,8	250	50,3	21,00

Vorschweissbund DIN

kurze Schenkel

mechanisch gefertigt

Stumpfschweissung

PE 100-RC schwarz

Stub Flange DIN

short spigot

machined

Butt-welding

PE 100-RC black

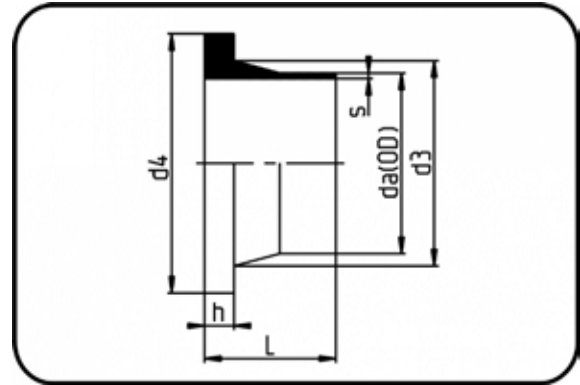

Code: 312

Dimension Dimension	Code Code	Detail Detail	da(OD) mm	s mm	L mm	d3 mm	d4 mm	h mm	Gewicht Weight
140	70.312.0140.09	140X15,7 SDR9 ISO S-4	140	15,7	95	155	188	30	0,90
180	70.312.0180.09	180X20,1 SDR9 ISO S-4	180	20,1	100	183	212	35	1,00
250	70.312.0250.09	250x27,9 SDR9 ISO S-4	250	27,9	130	285	320	41	4,00
280	70.312.0280.09	280x31,3 SDR9 ISO S-4	280	31,3	130	291	320	45	4,20
315	70.312.0315.09	315x35,2 SDR9 ISO S-4	315	35,2	136	335	370	47	5,80
355	70.312.0355.09	355x39,7 SDR9 ISO S-4	355	39,7	150	373	430	52	8,60
400	70.312.0400.09	400X44,7 SDR9 ISO S-4	400	44,7	155	427	482	58	11,40
450	70.312.0450.09	450x50,3 SDR9 ISO S-4	450	50,3	166	514	585	69	19,00
500	70.312.0500.09	500x55,8 SDR9 ISO S-4	500	55,8	175	530	585	71	18,50

Flansche finden Sie bitte unter Zubehör.

Backing Rings please see Accessories.

Product range 250 psi

Vorschweissbund ANSI

kurze Schenkel

mechanisch gefertigt

Stumpfschweissung

PE 100-RC schwarz

Stub Flange ANSI

short spigot

machined

Butt-welding

PE 100-RC black

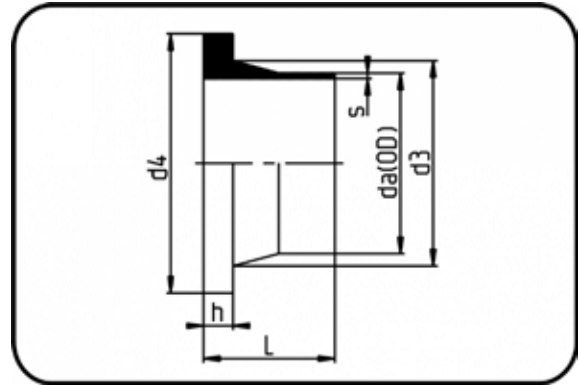

Code: 314

Dimension Dimension	Code Code	Detail Detail	da(OD) mm	s mm	L mm	d3 mm	d4 mm	h mm	Gewicht Weight
63	70.314.0063.09	63x7,1 SDR9 ISO S-4	63	7,1	118	75	100,4	14	0,20
75	70.314.0075.09	75x8,4 SDR9 ISO S-4	75	8,4	128	89	117	16	0,30
90	70.314.0090.09	90x10,1 SDR9 ISO S-4	90	10,1	140	105	132,4	17	0,51
110	70.314.0110.09	110x12,3 SDR9 ISO S-4	110	12,3	140	125	170,5	18	0,81
160	70.314.0160.09	160x17,9 SDR9 ISO S-4	160	17,9	181,5	175	219,6	25	2,00
200	70.314.0200.09	200x22,4 SDR9 ISO S-4	200	22,4	180,5	232	276,5	32	3,40
225	70.314.0225.09	225x25,2 SDR9 ISO S-4	225	25,2	212	235	276,5	32	4,16
250	70.314.0250.09	250x27,9 SDR9 ISO S-4	250	27,9	130	285	337	41	4,35
315	70.314.0315.09	315x35,2 SDR9 ISO S-4	315	35,2	136	335	406	47	6,80
355	70.314.0355.09	355x39,7 SDR9 ISO S-4	355	39,7	150	373	445	52	9,00
400	70.314.0400.09	400x44,7 SDR9 ISO S-4	400	44,7	155	427	510	58	12,60
450	70.314.0450.09	450x50,3 SDR9 ISO S-4	450	50,3	166	488	545	69	16,00
500	70.314.0500.09	500x55,8 SDR9 ISO S-4	500	55,8	175	530	600	71	18,50

Flansche finden Sie bitte unter Zubehör.

Backing Rings please see Accessories.

Endkappe

kurze Schenkel

mechanisch gefertigt

Stumpfschweissung

PE 100-RC schwarz

End Cap

short spigot

machined

Butt-welding

PE 100-RC black

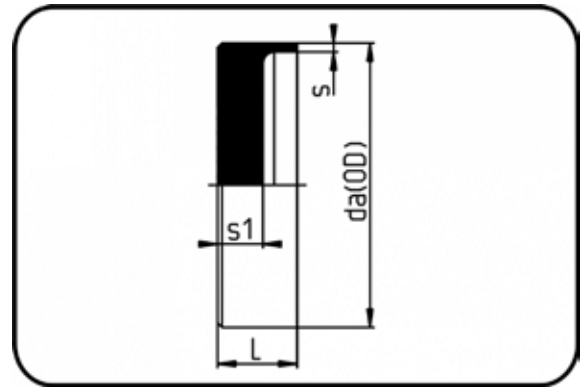

Code: 302

Dimension Dimension	Code Code	Detail Detail	da(OD) mm	s mm	L mm	s1 mm	Gewicht Weight
250	70.302.0250.09	250x27,9 SDR9 ISO S-4	250	27,9	80	55	2,90
280	70.302.0280.09	280x31,3 SDR9 ISO S-4	280	31,3	80	55	4,50
315	70.302.0315.09	315x35,2 SDR9 ISO S-4	315	35,2	85	60	5,10
355	70.302.0355.09	355x39,7 SDR9 ISO S-4	355	39,7	90	65	6,50
400	70.302.0400.09	400x44,7 SDR9 ISO S-4	400	44,7	95	70	7,80
450	70.302.0450.09	450x50,3 SDR9 ISO S-4	450	50,3	110	85	9,20
500	70.302.0500.09	500x55,8 SDR9 ISO S-4	500	55,8	120	95	10,40

Product range 250 psi

Bogen 90°

7 Segmente
druckklassengerecht
segmentiert

**Stumpf + E-
Muffenschweissung**
PE 100-RC schwarz

Bend 90°

7 segments
full pressure rated
segmented

Butt + E-socket-welding
PE 100-RC black

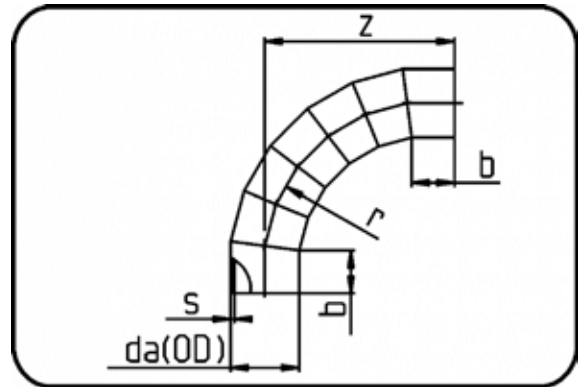

Code: 328

Dimension Dimension	Code Code	Detail Detail	da(OD) mm	s mm	r mm	b mm	t1 mm	z mm	Gewicht Weight
140	70.328.0140.09	140x15,7 SDR9 ISO S-4	140	15,7	450	115	100	515	5,80
250	70.328.0250.09	250x27,9 SDR9 ISO S-4	250	27,9	581	175	120	696	27,13
280	70.328.0280.09	280x31,3 SDR9 ISO S-4	280	31,3	596	175	120	711	34,69
315	70.328.0315.09	315x35,2 SDR9 ISO S-4	315	35,2	613	175	120	728	44,74
355	70.328.0355.09	355x39,7 SDR9 ISO S-4	355	39,7	1.127	300	250	1.302	93,60
400	70.328.0400.09	400x44,7 SDR9 ISO S-4	400	44,7	1.149	300	250	1.324	120,50
450	70.328.0450.09	450x50,3 SDR9 ISO S-4	450	50,3	1.174	300	250	1.349	155,03
500	70.328.0500.09	500x55,8 SDR9 ISO S-4	500	55,8	1.199	300	250	1.374	194,14

Bogen 45°

4 Segmente
druckklassengerecht
segmentiert

**Stumpf + E-
Muffenschweissung**
PE 100-RC schwarz

Bend 45°

4 segments
full pressure rated
segmented

Butt + E-socket-welding
PE 100-RC black

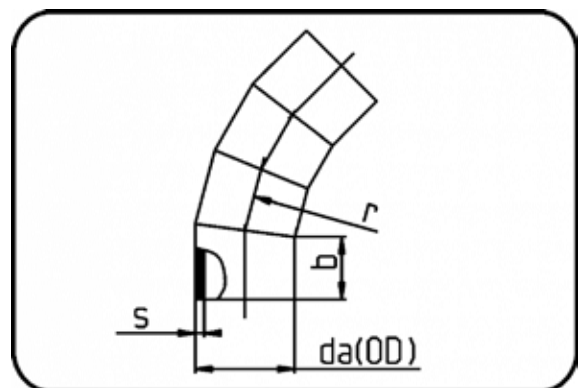

Code: 327

Dimension Dimension	Code Code	Detail Detail	da(OD) mm	s mm	r mm	b mm	t1 mm	z mm	Gewicht Weight
140	70.327.0140.09	140x15,7 SDR9 ISO S-4	140	15,7	450	115	100	239	3,10
250	70.327.0250.09	250x27,9 SDR9 ISO S-4	250	27,9	581	175	120	356	15,82
280	70.327.0280.09	280x31,3 SDR9 ISO S-4	280	31,3	596	175	120	362	20,18
315	70.327.0315.09	315x35,2 SDR9 ISO S-4	315	35,2	613	175	120	369	25,93
355	70.327.0355.09	355x39,7 SDR9 ISO S-4	355	39,7	1.127	300	642	642	53,70
400	70.327.0400.09	400x44,7 SDR9 ISO S-4	400	44,7	1.149	300	250	651	69,00
450	70.327.0450.09	450x50,3 SDR9 ISO S-4	450	50,3	1.174	300	250	661	88,64
500	70.327.0500.09	500x55,8 SDR9 ISO S-4	500	55,8	1.199	300	250	672	110,70

Product range 250 psi

T-Stück segmentiert

SDR7,4 ausgedreht auf SDR9
FM 218 PSI / 15 bar

**Stumpf + E-
Muffenschweissung**

PE 100-RC schwarz

Tee segmented

SDR7,4 machined to SDR9
FM 218 PSI / 15 bar

Butt + E-socket-welding

PE 100-RC black

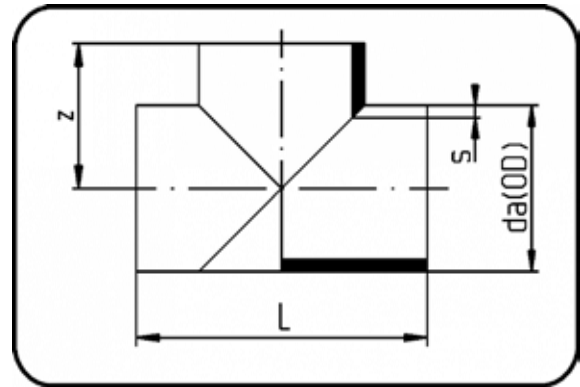

Code: 326

Dimension Dimension	Code Code	Detail Detail	da(OD) mm	s mm	z mm	L mm	Gewicht Weight
250	70.326.0250.09	250x27,9 SDR9 ISO S-4	250	27,9	265	530	12,50
280	70.326.0280.09	280x31,3 SDR9 ISO S-4	280	31,3	290	580	17,20
315	70.326.0315.09	315x35,2 SDR9 ISO S-4	315	35,2	327,5	655	23,80
355	70.326.0355.09	355x39,7 SDR9 ISO S-4	355	39,7	357,5	715	33,90
400	70.326.0400.09	400x44,7 SDR9 ISO S-4	400	44,7	400	800	47,30
450	70.326.0450.09	450x50,3 SDR9 ISO S-4	450	50,3	450	900	66,00
500	70.326.0500.09	500x55,8 SDR9 ISO S-4	500	55,8	485	970	88,70

Product range 250 psi

E-Muffe

MOP Wasser 25bar / Gas 10bar
MOP Wasser ÖVGW 16bar

formgespritzt

Heizwendel-Schweissung

PE 100-RC schwarz

E-Coupler

MOP water 25bar/gas 10bar
MOP water ÖVGW 16bar

injection moulded

Electro-fusion

PE 100-RC black

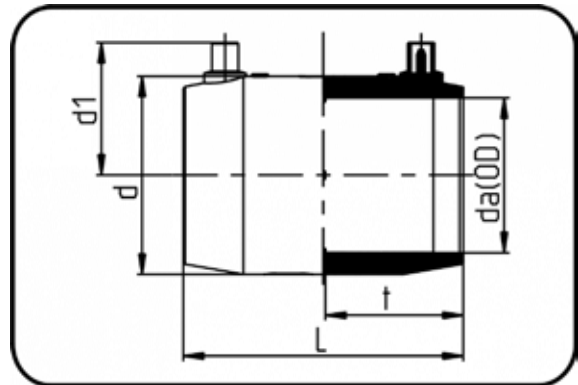

Code: 173

Dimension Dimension	Code Code	Detail Detail	da(OD) mm	L mm	d mm	d1 mm	t mm	Gewicht Weight
63	70.173.0063.11	63 SDR 17-7,4	63	124,5	83	59	62	0,26
75	70.173.0075.11	75 SDR 17-7,4	75	139,5	97	65,5	68,5	0,37
90	70.173.0090.11	90 SDR 17-7,4	90	138,5	112	72	68	0,44
110	70.173.0110.11	110 SDR 17-7,4	110	149	136	83	73	0,69
125	70.173.0125.11	125 SDR 17-7,4	125	169,5	155	91	83,5	0,99
140	70.173.0140.11	140 SDR 17-7,4	140	180	180	99	89,5	1,37
160	70.173.0160.11	160 SDR 17-7,4	160	180	197	109	88	1,76
180	70.173.0180.11	180 SDR 26-7,4	180	199,5	221	119	97,5	2,46
200	70.173.0200.11	200 SDR 26-7,4	200	215,5	245	127	105	3,14
225	70.173.0225.11	225 SDR 26-7,4	225	229	275	142	112	4,22
250	70.173.0250.11	250 SDR 26-7,4	250	238	310	155	116,5	4,81
280	70.173.0280.11	280 SDR 26-7,4	280	249	346	180	121,5	7,70
315	70.173.0315.11	315 SDR 26-7,4	315	260	390	187	127,5	7,89

E-Muffe

MOP Wasser 16bar / Gas 10bar

formgespritzt

Heizwendel-Schweissung

PE 100-RC schwarz

E-Coupler

MOP water 16bar/gas 10bar

injection moulded

Electro-fusion

PE 100-RC black

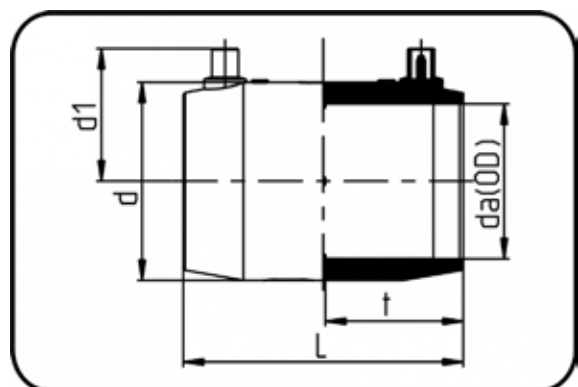

Code: 173

Dimension Dimension	Code Code	Detail Detail	da(OD) mm	L mm	d mm	d1 mm	t mm	Gewicht Weight
355	70.173.0355.11	355 SDR 26-11	355	280	445	225	136,5	14,75
400	70.173.0400.11	400 SDR 26-11	400	300	499	254	146,5	19,80
450	70.173.0450.11	450 SDR 17-11	450	338	552	260	166	20,60
500	70.173.0500.11	500 SDR 17-11	500	358	604	289	178,5	25,17

Product range 250 psi

E-Winkel 90°

MOP Wasser 16bar / Gas 10bar

formgespritzt

Heizwendel-Schweissung

PE 100-RC schwarz

E-Elbow 90°

MOP water 16bar/gas 10bar

injection moulded

Electro-fusion

PE 100-RC black

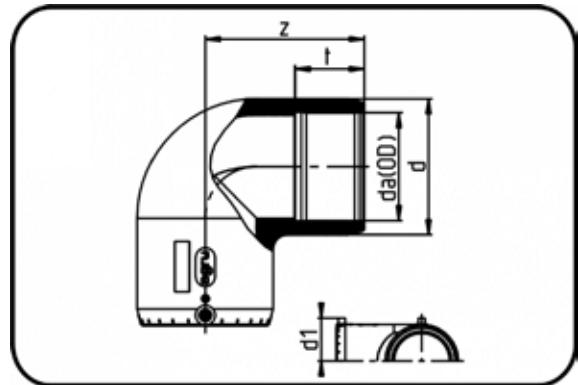

Code: 171

Dimension Dimension	Code Code	Detail Detail	da(OD) mm	z mm	d mm	d1 mm	t mm	Gewicht Weight
63	70.171.0063.11	63 SDR 17-11	63	99	83	60	62,7	0,39
75	70.171.0075.11	75 SDR 17-11	75	114	97	66	70	0,61
90	70.171.0090.11	90 SDR 17-11	90	147	114	73	70,5	1,06
110	70.171.0110.11	110 SDR 17-11	110	164	140	82,5	70,5	1,80
125	70.171.0125.11	125 SDR 17-11	125	164	161	91	84	2,46
160	70.171.0160.11	160 SDR 17-11	160	222	200	109	87	4,70
180	70.171.0180.11	180 SDR 26-11	180	230	224	118	98,5	6,25
200	70.171.0200.11	200 SDR 26-11	200	250	248	129,5	106,5	8,00
225	70.171.0225.11	225 SDR 17-11	225	274	279	144	112,5	10,80

E-Winkel 45°

MOP Wasser 16bar / Gas 10bar

formgespritzt

Heizwendel-Schweissung

PE 100-RC schwarz

E-Elbow 45°

MOP water 16bar/gas 10bar

injection moulded

Electro-fusion

PE 100-RC black

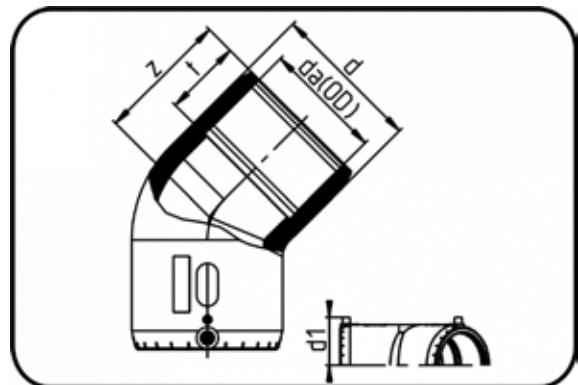

Code: 170

Dimension Dimension	Code Code	Detail Detail	da(OD) mm	z mm	d mm	d1 mm	t mm	Gewicht Weight
63	70.170.0063.11	63 SDR 17-11	63	82	82,5	58,5	61,5	0,33
75	70.170.0075.11	75 SDR 17-11	75	94	97	66	68,5	0,50
90	70.170.0090.11	90 SDR 17-11	90	113	115	74	71	0,85
110	70.170.0110.11	110 SDR 17-11	110	124	140	82,5	72	1,44
125	70.170.0125.11	125 SDR 17-11	125	124	161	92	85	1,91
160	70.170.0160.11	160 SDR 17-11	160	161,5	200	112	89	3,40
180	70.170.0180.11	180 SDR 26-11	180	172	224	119	98	4,89
200	70.170.0200.11	200 SDR 26-11	200	178	248,5	130,5	106,5	6,00
225	70.170.0225.11	225 SDR 17-11	225	190	279	145,5	113,5	7,99

E-Reduktion konzentrisch E-Reducer concentric

MOP Wasser 16bar / Gas 10bar MOP water 16bar/gas 10bar

formgespritzt

injection moulded

Heizwendel-Schweissung Electro-fusion

PE 100-RC schwarz PE 100-RC black

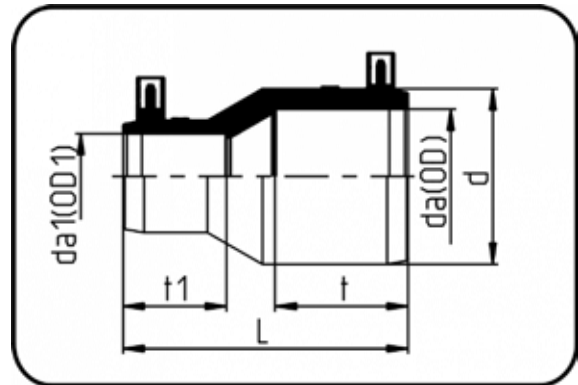

Code: 177

Dimension Dimension	Code Code	Detail Detail	da(OD) mm	da1(OD1) mm	L mm	d mm	t mm	t1 mm	Gewicht Weight
90/63	70.177.9063.11	90/63 SDR 17-11	90	63	171,5	117	71,5	62,5	0,56
110/63	70.177.1163.11	110/63 SDR 17-11	110	63	200,5	140,5	72	62,5	0,86
110/90	70.177.1190.11	110/90 SDR 17-11	110	90	180,5	140,5	72	71	0,94
125/90	70.177.1290.11	125/90 SDR 17-11	125	90	183,5	156	83	68,7	0,99
125/110	70.177.1211.11	125/110 SDR 17-11	125	110	173,5	156	82	69,5	1,05
160/90	70.177.1690.11	160/90 SDR 17-11	160	90	240,5	200	89,5	71	1,89
160/110	70.177.1611.11	160/110 SDR 17-11	160	110	224,5	200	89,5	71	1,98
225/160	70.177.2216.11	225/160 SDR 17-11	225	160	282	280	113	88	5,12

E-Endkappe

MOP Wasser 16bar / Gas 10bar

formgespritzt

Heizwendel-Schweissung

PE 100-RC schwarz

E-End Cap

MOP water 16bar/gas 10bar

injection moulded

Electro-fusion

PE 100-RC black

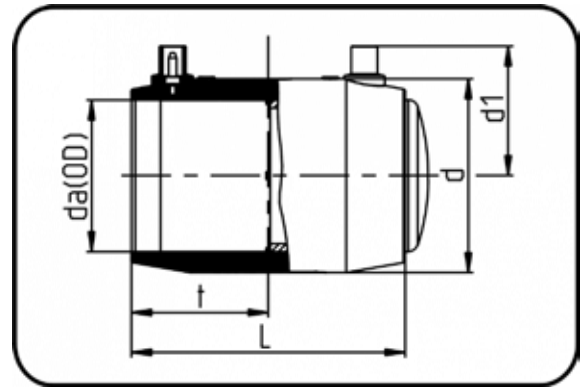

Code: 174

Dimension Dimension	Code Code	Detail Detail	da(OD) mm	L mm	d mm	d1 mm	t mm	Gewicht Weight
63	70.174.0063.11	63 SDR 17-11	63	124,5	83	59	62	0,35
75	70.174.0075.11	75 SDR 17-11	75	139,5	97	65,5	68,5	0,50
90	70.174.0090.11	90 SDR 17-11	90	138,5	112	72	68	0,69
110	70.174.0110.11	110 SDR 17-11	110	149	136	83	73	1,23
125	70.174.0125.11	125 SDR 17-11	125	169,5	155	91	83,5	1,62
140	70.174.0140.11	140 SDR 17-11	140	180	180	99	88,5	2,40
160	70.174.0160.11	160 SDR 17-11	160	180	197	107,5	88	2,92
180	70.174.0180.11	180 SDR 26-11	180	199,5	221	119	97,5	3,92
200	70.174.0200.11	200 SDR 17-11	200	215,5	245	127	105	5,21
225	70.174.0225.11	225 SDR 17-11	225	229	275	142	112	7,20
250	70.174.0250.11	250 SDR 26-11	250	238	310	155	116,5	8,84
280	70.174.0280.11	280 SDR 26-11	280	249	346	180	121,5	12,66
315	70.174.0315.11	315 SDR 26-11	315	260	386	187	127,5	14,70

Product range 250 psi

**Stutzenschelle System
Topload**

mechanisch gefertigt

Heizwendel-Schweissung

PE 100-RC schwarz

**Spigot saddle System
Topload**

machined

Electro-fusion

PE 100-RC black

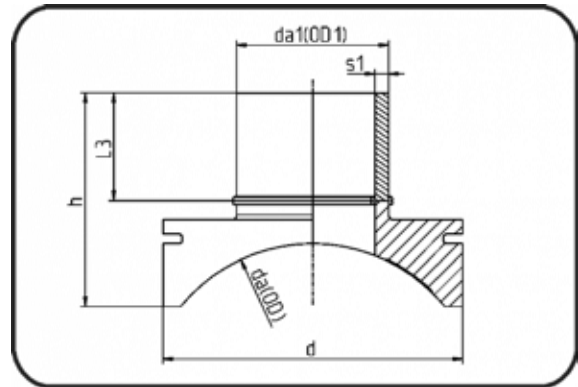

Code: 289

Dimension Dimension	Code Code	Detail Detail	da(OD) mm	da1(OD1) mm	h mm	d mm	s1 mm	L3 mm	Gewicht Weight
355/90	70.289.3590.09	355/90 SDR9 ISO S-4	355	90	176	200	10,1	94	3,42
355/110	70.289.3511.09	355/110 SDR9 ISO S-4	355	110	194	250	12,3	97	3,42
355/125	70.289.3512.09	355/125 SDR9 ISO S-4	355	125	209	280	14	102	3,42
400/90	70.289.4090.09	400/90 SDR9 ISO S-4	400	90	173	200	10,1	94	3,42
400/110	70.289.4011.09	400/110 SDR9 ISO S-4	400	110	189	250	12,3	97	3,42
400/125	70.289.4012.09	400/125 SDR9 ISO S-4	400	125	204	280	14	102	3,42
450/90	70.289.4590.09	450/90 SDR9 ISO S-4	450	90	171	200	10,1	94	3,42
450/110	70.289.4511.09	450/110 SDR9 ISO S-4	450	110	186	250	12,3	97	3,42
450/125	70.289.4512.09	450/125 SDR9 ISO S-4	450	125	199	280	14	102	3,42
500/90	70.289.5090.09	500/90 SDR9 ISO S-4	500	90	168	200	10,1	94	3,42
500/110	70.289.5011.09	500/110 SDR9 ISO S-4	500	110	182	250	12,3	97	3,42
500/125	70.289.5012.09	500/125 SDR9 ISO S-4	500	125	195	280	14	102	3,42

MOP auf Anfrage. Spannvorrichtung siehe bitte unter Schweisstechnik.

MOP on request. Installation Set please see Welding Technology.

Losflansch DIN

Stahleinlage/für V-Bund

formgespritzt+gebohrt PN10/16

Flanschverbindung

PP-GFK schwarz

Backing Ring DIN

steel insert/for stub flange

inj. moulded+drilled PN10/16

Flange connection

PP-FRP black

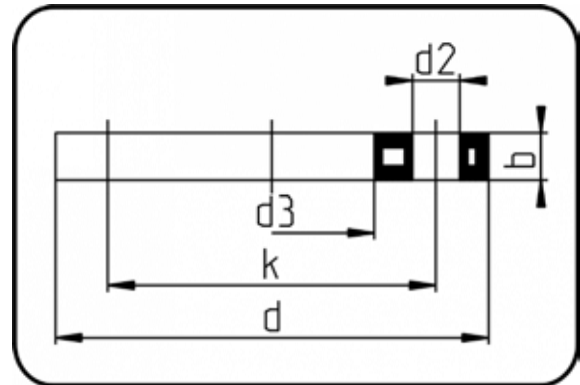

Code: 14.014

Dimension Dimension	Code Code	Detail Detail	da(OD) mm	d mm	d2 mm	d3 mm	b mm	k mm	Gewicht Weight
63	14.014.0063.11	63 - MOP 16 bar	63	165	18	78	18	125	0,79
75	14.014.0075.11	75 - MOP 16 bar	75	186	18	92	18	145	1,11
90	14.014.0090.11	90 - MOP 16 bar	90	202	18	108	20	160	1,16
110	14.014.0110.11	110 - MOP 16 bar	110	220	18	128	20	180	1,33
125	14.014.0125.11	125 - MOP 16 bar	125	220	18	135	20	180	1,22
140	14.014.0140.11	140 - MOP 16 bar	140	250	18	158	24	210	1,94
160	14.014.0160.11	160 - MOP 16 bar	160	285	22	178	23	240	2,60
180	14.014.0180.11	180 - MOP 16 bar	180	285	22	190	23	240	2,24

Losflansch DIN

Stahleinlage/für V-Bund

formgespritzt+gebohrt PN10

Flanschverbindung

PP-GFK schwarz

Backing Ring DIN

steel insert/for stub flange

injection moulded+drilled PN10

Flange connection

PP-FRP black

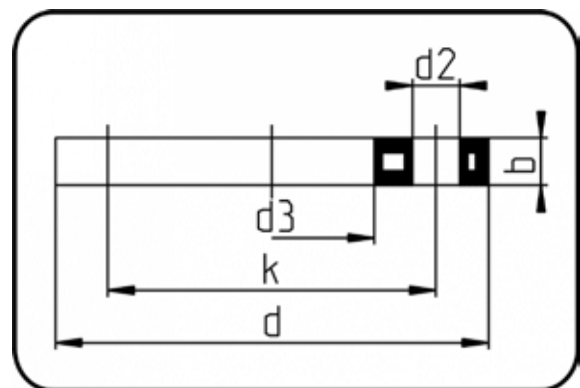

Code: 14.014

Dimension Dimension	Code Code	Detail Detail	da(OD) mm	d mm	d2 mm	d3 mm	b mm	k mm	Gewicht Weight
200	14.014.0200.11	200 - MOP 16 bar	200	340	22	235	25	295	2,66
225	14.014.0225.11	225 - MOP 16 bar	225	340	22	238	25	295	2,80
250	14.014.0250.11	250 - MOP 16 bar	250	409	22	288	30	350	6,40
280	14.014.0280.11	280 - MOP 16 bar	280	409	22	294	30	350	6,40
315	14.014.0315.11	315 - MOP 16 bar	315	463	23	338	34	400	9,60
355	14.014.0355.11	355 - MOP 16 bar	355	515	22,5	376	42	460	14,60
400	14.014.0400.11	400 - MOP 16 bar	400	574	26	430	46	515	17,74
450	14.014.0450.11	450/DN500 - MOP 16 bar	450	678	26	517	45	620	24,96
500	14.014.0500.11	500 - MOP 16 bar	500	678	26	533	45	620	24,38
560	14.014.0560.11	560 - MOP 10 bar	560	789	30	618	50	725	33,40
630	14.014.0630.11	630 - MOP 10 bar	630	789	30	645	50	725	32,62

Losflansch DIN

Stahleinlage/für V-Bund

formgespritzt+gebohrt PN16

Flanschverbindung

PP-GFK schwarz

Backing Ring DIN

steel insert/for stub flange

injection moulded+drilled PN16

Flange connection

PP-FRP black

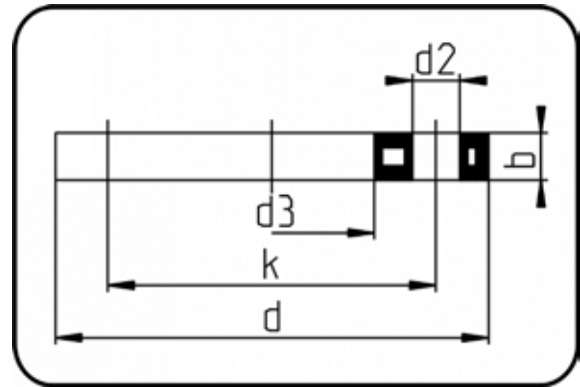

Code: 14.014.1

Dimension Dimension	Code Code	Detail Detail	da(OD) mm	d mm	d2 mm	d3 mm	b mm	k mm	Gewicht Weight
200	14.014.1200.11	200 - MOP 16 bar	200	340	22	235	24	295	3,00
225	14.014.1225.11	225 - MOP 16 bar	225	340	22	238	24	295	2,85
250	14.014.1250.11	250 - MOP 16 bar	250	418	26	288	30	355	7,00
280	14.014.1280.11	280 - MOP 16 bar	280	418	26	294	30	355	6,80
315	14.014.1315.11	315 - MOP 16 bar	315	478	26	338	30	410	8,40
355	14.014.1355.11	355 - MOP 16 bar	355	530	26	376	42	470	16,70
400	14.014.1400.11	400 - MOP 16 bar	400	599	30	430	41	525	17,00

Blindflansch DIN

Stahleinlage

formgespritzt+gebohrt PN10/16

Flanschverbindung

PP-GFK schwarz

Blind Flange DIN

steel insert

inj. moulded+drilled PN10/16

Flange connection

PP-FRP black

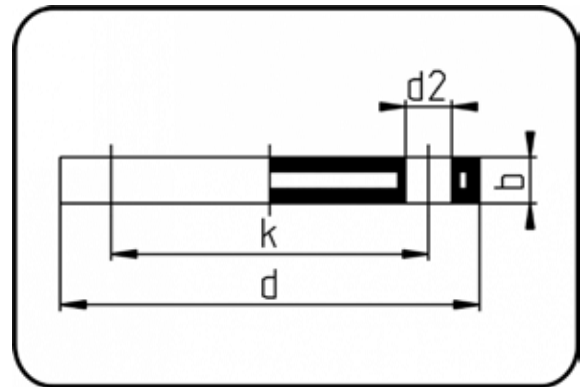

Code: 14.045

Dimension Dimension	Code Code	Detail Detail	da(OD) mm	d mm	d2 mm	b mm	k mm	p bar	Gewicht Weight
63	14.045.0063.11	63 - MOP 16 bar	63	165	18	17	125	16	1,15
75	14.045.0075.11	75 - MOP 16 bar	75	185,5	18	19	145	16	1,64
90	14.045.0090.11	90 - MOP 16 bar	90	202	18	20	160	16	1,96
110/125	14.045.0110.11	110/125 - MOP 16 bar	110	220	18	20	180	16	2,36
140	14.045.0140.11	140 - MOP 16 bar	140	250	18	24,5	210	16	3,92
160/180	14.045.0160.11	160/180 - MOP 16 bar	160	285	22	23	240	16	5,06

Product range 250 psi

Blindflansch DIN

Stahleinlage

formgespritzt+gebohrt PN10

Flanschverbindung

PP-GFK schwarz

Blind Flange DIN

steel insert

injection moulded+drilled PN10

Flange connection

PP-FRP black

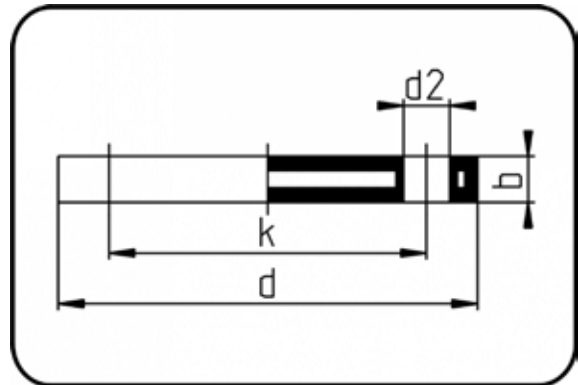

Code: 14.045

Dimension Dimension	Code Code	Detail Detail	da(OD) mm	d mm	d2 mm	b mm	k mm	p bar	Gewicht Weight
200/225	14.045.0200.11	200/225 - MOP 16 bar	200	340	22	25	295	16	6,50
250/280	14.045.0250.11	250/280 - MOP 10 bar	250	409	22	30	350	10	15,40
315	14.045.0315.11	315 - MOP 10 bar	315	463	22	34	400	10	26,00
355	14.045.0355.11	355 - MOP 10 bar	355	515	22	42	460	10	39,66
400	14.045.0400.11	400 - MOP 10 bar	400	574	27	46	515	10	50,44

Blindflansch DIN

Stahl verzinkt

gebohrt PN10

Flanschverbindung

Stahl verzinkt

Blind Flange DIN

steel galvanized

drilled PN10

Flange connection

steel galvanized

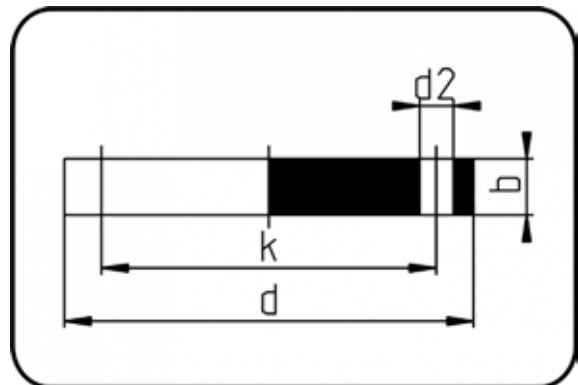

Code: 90.045

Dimension Dimension	Code Code	Detail Detail	da(OD) mm	d mm	d2 mm	b mm	k mm	Gewicht Weight
450/500	90.045.0450.17	450/500 - MOP 16 bar	450	670	26	28	620	124,00

** Auf Anfrage.

** On request.

Product range 250 psi

Losflansch ANSI

Stahleinlage

formgespritzt

Flanschverbindung

PP-GFK grau

Backing Ring ANSI

steel insert

injection moulded

Flange connection

PP-FRP grey

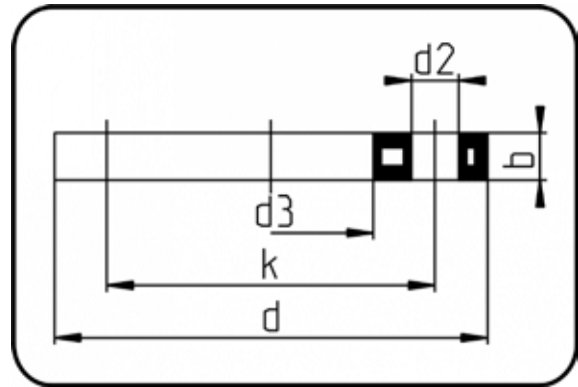

Code: 11.013

Dimension Dimension	Code Code	Detail Detail	da(OD) mm	d mm	d2 mm	d3 mm	b mm	k mm	Gewicht Weight
63	11.013.0063.11	63 - 2" - MOP 16 bar	63	162	20	78	18	120,65	0,81
75	11.013.0075.11	75 - 2 1/2" - MOP 16 bar	75	184	20	92	18	139,7	1,07
90	11.013.0090.11	90 - 3" - MOP 16 bar	90	194	20	111	18	152,4	1,03
110/125	11.013.0110.11	110/125 - 4" - MOP 16 bar	110	229	20	133	18	190,5	1,55
160	11.013.0160.11	160 - 6" - MOP 16 bar	160	283	22	178	24	241,3	2,32
200/225	11.013.0200.11	200/225 - 8" - MOP 16 bar	200	345	22	236	24	298,45	3,43
250/280	11.013.0250.11	250/280 - 10" - MOP 16 bar	250	412	25	288	26	361,95	6,10
315	11.013.0315.11	315 - 12" - MOP 16 bar	315	487	25	338	32	431,8	13,00

Losflansch ANSI

Stahleinlage

formgespritzt

Flanschverbindung

PP-GFK schwarz

Backing Ring ANSI

steel insert

injection moulded

Flange connection

PP-FRP black

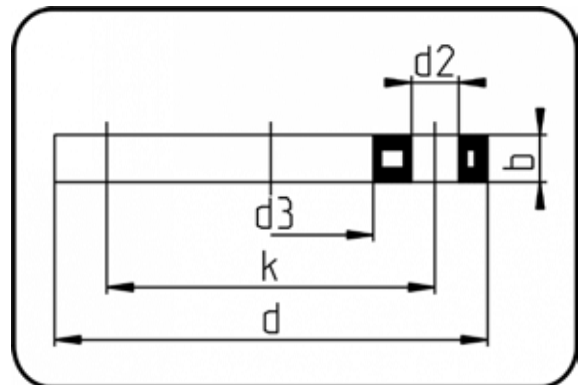

Code: 013

Dimension Dimension	Code Code	Detail Detail	da(OD) mm	d mm	d2 mm	d3 mm	b mm	k mm	Gewicht Weight
63	14.013.0063.11	63 - 2" - MOP 16 bar	63	162	20	78	18	120,65	0,81
75	14.013.0075.11	75 - 2 1/2" - MOP 16 bar	75	184	20	92	18	139,7	1,07
90	14.013.0090.11	90 - 3" - MOP 16 bar	90	194	20	111	18	152,4	1,08
110/125	14.013.0110.11	110/125 - 4" - MOP 16 bar	110	229	20	133	18	190,5	1,56
160	14.013.0160.11	160 - 6" - MOP 16 bar	160	283	22	178	24	241,3	2,35
200/225	14.013.0200.11	200/225 - 8" - MOP 16 bar	200	345	22	236	24	298,45	3,39
250/280	14.013.0250.11	250/280 - 10" - MOP 16 bar	250	412	25	288	26	361,95	6,20
315	14.013.0315.11	315 - 12" - MOP 16 bar	315	487	25	338	32	431,8	12,60

Product range 250 psi

Losflansch ANSI

Stahl verzinkt

ASME B16.5 Class 150

Flanschverbindung

Stahl verzinkt

Backing Ring ANSI

steel galvanized

ASME B16.5 Class 150

Flange connection

steel galvanized

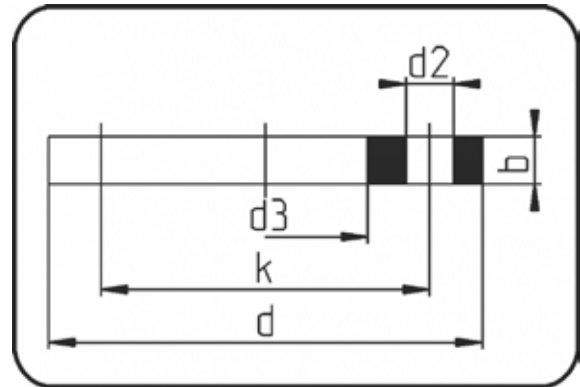

Code: 90.013

Dimension Dimension	Code Code	Detail Detail	da(OD) mm	d mm	d2 mm	d3 mm	b mm	k mm	Gewicht Weight
355	90.013.0355.17	355 - 14" MOP 20 bar	355	535	29	376	33,4	476,25	28,00
400	90.013.0400.17	400 - 16" MOP 20 bar	400	595	29	430	35	539,75	34,00
450	90.013.0450.17	450 - 18" MOP 20 bar	450	635	32	492	38,1	577,85	42,03
500	90.013.0500.17	500 - 20" MOP 20 bar	500	700	32	533	41,3	635	47,00
560	90.013.0560.17	560 - 22" MOP 20 bar	560	750	35	618	30,2	692,15	45,40
630	90.013.0630.17	630 - 24" MOP 20 bar	560	815	35	645	46,1	749,3	58,03

** Auf Anfrage.

** On request.

Blindflansch ANSI

Stahleinlage

formgespritzt

Flanschverbindung

PP-GFK grau

Blind Flange ANSI

steel insert

injection moulded

Flange connection

PP-FRP grey

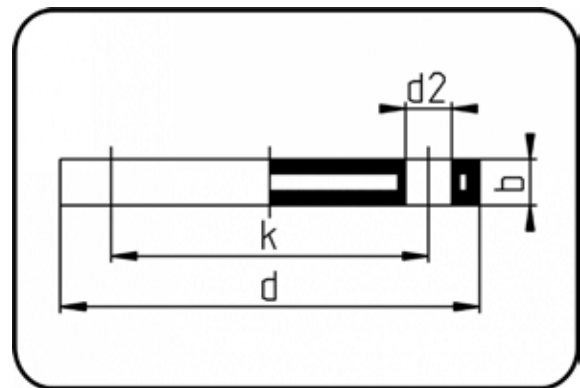

Code: 11.043

Dimension Dimension	Code Code	Detail Detail	da(OD) mm	d mm	d2 mm	b mm	k mm	Gewicht Weight
63	11.043.0063.11	63 - 2" - MOP 16 bar	63	162	20	18,5	120,65	1,22
75	11.043.0075.11	75 - 2 1/2" - MOP 16 bar	75	184	20	18	139,7	1,54
90	11.043.0090.11	90 - 3" - MOP 16 bar	90	194	20	18	152,4	1,84
110/125	11.043.0110.11	110/125 - 4" - MOP 16 bar	110	229	20	18	190,5	2,88
160	11.043.0160.11	160 - 6" - MOP 16 bar	160	283	22	24	241,3	5,10
200/225	11.043.0200.11	200/225 - 8" - MOP 16 bar	200	345	22	24	298,45	7,92
250/280	11.043.0250.11	250/280 - 10" - MOP 16 bar	250	412	25	27	361,95	15,15
315	11.043.0315.11	315 - 12" - MOP 16 bar	315	487	25	33	431,8	28,80

Blindflansch ANSI

Stahl verzinkt

ASME B16.5 Class 150

Flanschverbindung

Stahl verzinkt

Blind Flange ANSI

steel galvanized

ASME B16.5 Class 150

Flange connection

steel galvanized

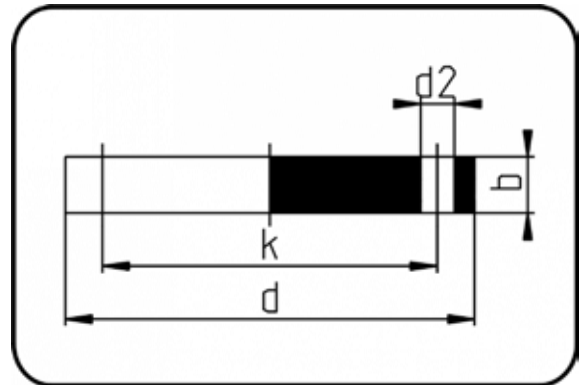

Code: 90.043

Dimension Dimension	Code Code	Detail Detail	da(OD) mm	d mm	d2 mm	b mm	k mm	Gewicht Weight
355	90.043.0355.17	355 - 14" MOP 20 bar	355	535	29	33,4	476,25	57,00
400	90.043.0400.17	400 - 16" MOP 20 bar	400	595	29	35	539,75	68,00
450	90.043.0450.17	450 - 18" MOP 20 bar	450	635	32	38,1	577,85	102,00
500	90.043.0500.17	500 - 20" MOP 20 bar	500	700	32	41,3	635	120,00

** Auf Anfrage.

** On request.

